

---

**User's  
Manual**

**YEW SERIES 80**

**Model SMRT  
(Style E)  
Ratio Set Station**

IM 1B4D4-02E

---

# Notices

## ■ Regarding This User's Manual

- (1) This manual should be passed on to the end user. Keep at least one extra copy of the manual in a safe place.
- (2) Read this manual carefully and fully understand how to operate this product before you start operation.
- (3) This manual is intended to describe the functions of this product. Yokogawa Electric Corporation (hereinafter simply referred to as Yokogawa) does not guarantee that the functions will suit a particular purpose of the user.
- (4) Under absolutely no circumstances may the contents of this manual in part or in whole be transcribed or copied without permission.
- (5) The contents of this manual are subject to change without prior notice.
- (6) Every effort has been made to ensure accuracy in the preparation of this manual. Should any error or omissions come to your attention however, please contact your nearest Yokogawa representative or our sales office.

## ■ Regarding Protection, Safety, and Prohibition against Unauthorized Modification

- (1) In order to protect the product and the system controlled by it against damage and ensure its safe use, make certain that all of the instructions and precautions relating to safety contained in this manual are strictly adhered to. Yokogawa does not guarantee safety if products are not handled according to these instructions.
- (2) Be sure to use the spare parts approved by Yokogawa when replacing parts or consumables.
- (3) Modification of the product is strictly prohibited.
- (4) Reverse engineering such as the disassembly or decompilation of software is strictly prohibited.
- (5) No portion of the software supplied by Yokogawa may be transferred, exchanged, leased or sublet for use by any third party without the prior permission of Yokogawa.

## ■ Force Majeure

- (1) Yokogawa does not make any warranties regarding the product except those mentioned in the WARRANTY that is provided separately.
- (2) Yokogawa assumes no liability to any party for any loss or damage, direct or indirect, caused by the user or any unpredictable defect of the product.



# CONTENTS

<i>Section</i>	<i>Title</i>	<i>Page</i>
1.	<b>INSPECTION.</b> .....	1-1
2.	<b>GENERAL.</b> .....	2-1
	2-1. Standard Specifications. ....	2-1
	2-2. Options. ....	2-2
	2-3. Spare Parts Supplied. ....	2-2
	2-4. Model and Suffix Codes. ....	2-2
3.	<b>INSTALLATION AND WIRING.</b> .....	3-1
	3-1. Installation. ....	3-1
	3-2. Wiring. ....	3-1
	3-3. Terminal Board Wiring. ....	3-2
4.	<b>BASIC OPERATION.</b> .....	4-1
	4-1. Description of Circuit Operation. ....	4-1
	4-1-1. Circuit Features. ....	4-1
	4-1-2. Control Loop Configuration Example. ....	4-1
	4-1-3. Circuit Operation. ....	4-1
5.	<b>OPERATION.</b> .....	5-1
	5-1. Front- and Side-Panel Features. ....	5-1
	5-1-1. Station Front Panel. ....	5-1
	5-1-2. Tuning Panel Configuration. ....	5-3
	5-1-3. Explanation of Keyboard Functions. ....	5-5
	5-1-4. Operation Mode Functions. ....	5-5
	5-1-5. Keyboard Operation. ....	5-8
	5-2. Preparations for Operations. ....	5-8
	5-2-1. Installing Special Parts. ....	5-9
	5-2-2. Preparations for Operation. ....	5-9
	5-3. Startup and Operation. ....	5-11
	5-3-1. Manual Startup. ....	5-11
	5-3-2. Alarm Check and Transfer to Automatic Operation. ....	5-11
	5-3-3. Normal Operation. ....	5-11
	5-4. Action to be Taken when FAIL or ALM Lamps Light. ....	5-11
	5-4-1. Action when the FAIL Lamp Lights. ....	5-11
	5-4-2. Action when the ALM Lamp Lights. ....	5-12
	5-4-3. Action when the ALM Lamp Flashes. ....	5-12
	5-4-4. CHECK Display. ....	5-13
	5-4-5. ALARM Display. ....	5-13
6.	<b>MAINTENANCE.</b> .....	6-1
	6-1. Equipment Required for Calibration. ....	6-1
	6-2. Indicator Inspection and Calibration. ....	6-1
	6-2-1. Process Variable Pointer Zero Adjustment. ....	6-1
	6-2-2. Adjusting the Setting Indicator Zero. ....	6-1
	6-2-3. Manipulated Output Indicator Zero Adjustment. ....	6-2
	6-2-4. Inclined Mounting. ....	6-2
	6-3. Parts Replacement. ....	6-2
	6-3-1. Replacing Nameplate. ....	6-2
	6-3-2. Replacing Scale Plate. ....	6-2
	6-3-3. Replacing Fuse. ....	6-3
	6-3-4. Replacing Data Memory Backup Battery. ....	6-3
	● Customer Maintenance Parts List.....	CMPL 1B4D4-03E
	● POWER SUPPLY TERMINALS for PANEL-MOUNTED INSTRUMENTS (for /HTB)	

**IM 1B4F1-11E**



## 1. INSPECTION.

This instrument was thoroughly tested at the factory before shipment. However, when you receive this instrument:

- (1) Inspect for visible damage.
- (2) Confirm that the model and suffix codes shown on the shipping documents, and also on the nameplate on the side panel, are the same as on your order sheet.
- (3) Confirm that all accessories (see Section 2-3) are present.

If you have any questions about this instrument, please contact either your nearest Yokogawa Sales & Service Office or Yokogawa Electric Corporation, Tokyo, Japan.

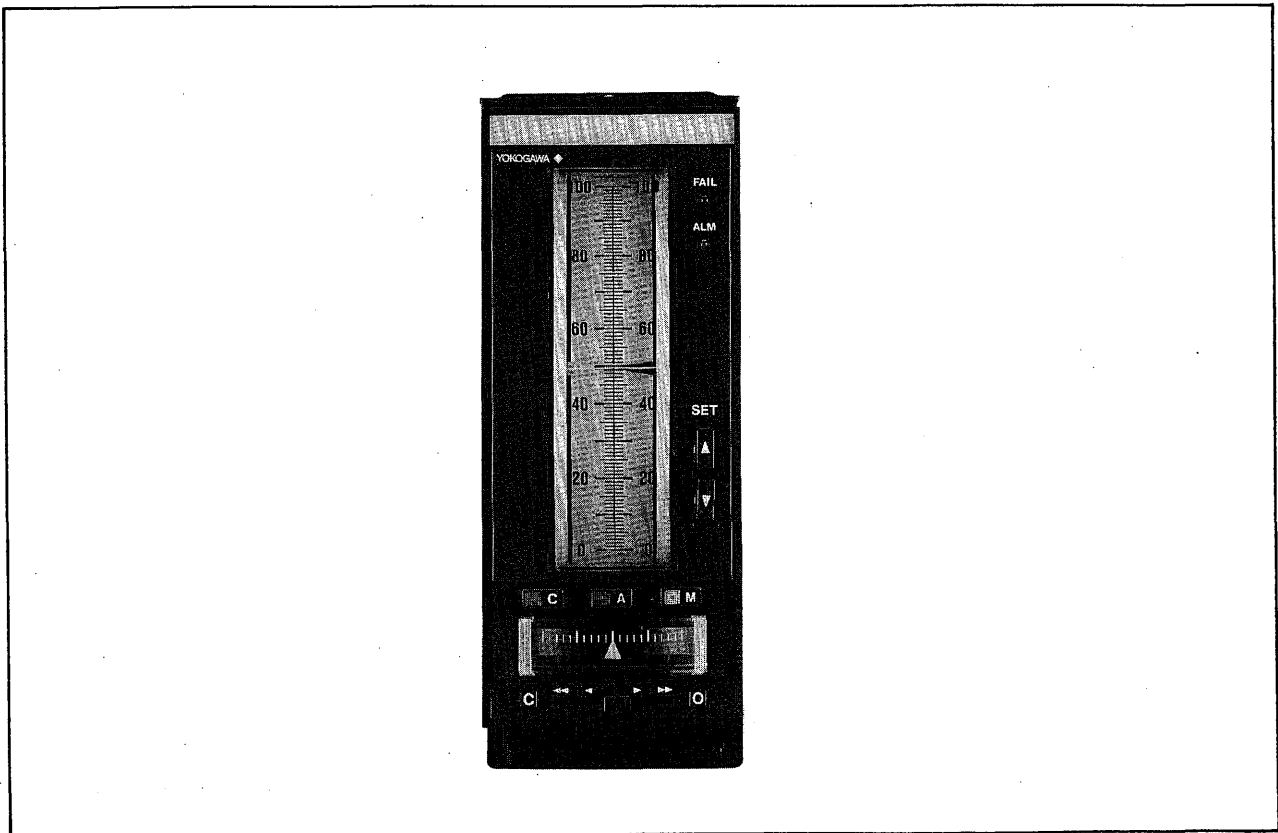

Figure 1-1. Model SMRT\*E Ratio Set Station.



## 2. GENERAL.

The SMRT Ratio Set Station is used in control systems in which two or more process variables must be held within a certain predetermined ratio. It has a broad range of application, such as flowrate ratio control and load distribution setting in boiler control.

- A built-in microprocessor enables the SMRT Ratio Set Station to cover a wide range of ratios.
- A single SMRT model can support two different computational expressions.
- Coefficients can be easily set with the side-panel pushbutton switches.

### 2-1. Standard Specifications.

#### Input and Output Signal Specifications

**Analog Input Signal:** 1 to 5V DC, 4 Points

**Analog Output Signal:** 1 to 5V DC, 2 Points  
4 to 20 mA DC, 1 point.

**Status Input Signal:** No-voltage or voltage contact, 2 points.

**Status Output Signal:** Transistor contact, 4 points.

**Fail Output Signal:** Transistor contact, 1 point.

#### Indicating, Setting, and Operating Functions

**Moving Coil Indicator:** Dual index (red/blue).

Red index: Process variable input or ratio value.

Blue index: Ratio set point or internal bias set point.

**Output Indicator:** Moving coil type, with two memory indexes and valve open/close indexes.

**Ratio Setting:** Manual and remote setting.

Manual setting: From front-panel pushbutton switches and tuning panel. Variable to 40 sec./full scale.

Remote setting: By remote ratio signals (in C mode only).

**Mode Transfer:** C mode (C)/Auto(A)/Manual(M).

Instrument front-panel pushbutton switches (with built-in indicator lamps) and external status inputs effect instrument mode transfers between these three modes.

**Manual Output:** Set by two-speed lever action.

**Setting Computational Coefficients/Parameters & Selecting Display Data:** Uses a 16-key keypad on the tuning panel (side panel).

**Mode Transfer by Status Input:**

External Mode Transfer:

EXT. MAN: (C, A)  $\longleftrightarrow$  M transfer:

During C or auto mode operation, manual (M) mode is established with contact input status being set to OFF.

EXT. AUT: C  $\longleftrightarrow$  A transfer.

During C mode operation, auto (A) mode is established with contact input status being set to OFF.

EXT. TRK: External signal tracking.

During auto or C mode operation, the output follows the output tracking input signal as contact input status is set to OFF.

**Preset MV:** During auto or C mode operation, output is set to a predetermined M (manual) mode output value as contact input status is set to ON or OFF.

Output setting range: -6.3 to 106.3 %.

**Mode Status Output:**

Mode	C	A	M
(C · A)/M Contact	Closed	Closed	Open
C/(A · M) Contact	Closed	Open	Open

#### Computational Functions

##### Ratio Expressions

Computational Expression A:

$$MV = SV_n (PV+P1) + P4 (EB+P2) + P3$$

Computational Expression B:

$$MV = SV_n \{ (PV+P1) + P4 (EB+P2) \} + P3$$

where,

MV: manipulated variable

PV: process variable

EB: external bias

SV<sub>n</sub>: internally computed ratio

P1 to P4: computational parameters

**Ratio Setting:**

Range: The high limit (SRH) and the low limit (SRL) of SV<sub>n</sub> can be set in the range from 0.000 to 8.000. However, SRH and SRL must satisfy the relationship SRH - SRL  $\geq$  0.1.

#### Alarm Functions

**Alarm Actions:** Process variable high/low limit alarms, ratio set point limit alarm.

**Output Contacts:** One each for high and low limit alarms (No ratio set point limit alarm output). An open or closed alarm contact can be selected from the tuning panel. Contact open during power failure.

**Alarm Indication:** Front-panel "ALM" lamp.



**Mounting**

**Mounting:** Flush panel mounting. Instruments are in housings, and can be mounted either separately or side-by-side. Instrument may be inclined up to 75° from vertical (rear of instrument lower than front). (Indicator zero may require readjustment.)

**Wiring:**

Signal Wiring to/from the Field: ISO M4 size (4mm) screws on terminal block.

**Power and Ground Wiring:**

100 V version: JIS C 8303 two-pin plug with earthing contact. (IEC A5-15, UL498)

220 V version: CEE 7 VII (CENELEC standard) plug.

Cable Length: 300 mm.

**Housing Dimensions:** 182.5 (H) × 87 (W) × 480 (D) (mm) D: depth behind panel.

**Weights:**

Controller Less Housing: 3.3 kg.

Housing: 2 kg (excluding mounting kit).

**Normal Operating Conditions**

**Ambient Temperature:** 0 to 50°C.

**Ambient Humidity:** 5 to 90% relative humidity (non-condensing).

**Power Supply:** Two versions, for "100 V" (standard) or "220 V" (option/A2ER). Both versions may use AC or DC, without change to the instrument:

Version	100 V	220 V
DC (polarity reversible)	20 to 130 V	120 to 340 V
AC (47 to 63 Hz)	80 to 138 V	138 to 264 V

**2-2. Options.**

/A2ER: For "220 V version" power supply.

/MTS: Station supplied with kit for separate mounting.

/SCF-G□M: Mounting kit bezel color change from standard color (black). Choose color from set of optional colors (see GS 22D1F1-E). Specify color code in the box □.

/NHS: No housing with instrument. See GS 1B3F1 to order housing separately.

/NPE: Engraved front-panel nameplate.

**2-3. Spare Parts Supplied.**

Fuse: 1A, quantity one.

Labels to Record Tuning Data: Two sheets.

Note: The fuse (S9510VK) is the dedicated fuse, Do not use it for other products.

**2-4. Model and Suffix Codes.**

Model	Suffix Codes	Description
SMRT	.....	Ratio Set Station
Process variable indicator	-1 .....	With process variable indicator
Function	4 .....	Enhanced type
	0 .....	Always 0
Style code	*E .....	Style E
Common options	/A2ER /MTS /SCF-G□M /NHS /NPE	220V power supply With mounting kit Bezel color change Without housing With engraved nameplate

### 3. INSTALLATION AND WIRING.

#### 3-1. Installation.

To install this instrument, refer to instruction manual IM 1B4F1-01E "Installation Manual for Panel-Mounted Instruments".

#### 3-2. Wiring.

Connect external wires to the terminal board on the rear of the housing with 4 mm screws. Table 3-1 shows the terminal connections for this station. Connect wires in accordance with the model and suffix codes.

##### Wiring Precautions:

- (1) Furnish all cable ends with solderless crimp-on lugs.
- (2) Connect external voltage-and/or no-voltage-levels contact input so that the values specified in Figures 3-1 and 3-2 are obtained. Conductor resistance and consequent voltage drop must be taken into account. For contact input specifications, refer to GS 1B4D4-E at the end of this manual.
- (3) When driving remote equipment such as fail and alarm outputs, using transistor switch contacts, wire in accordance with the following instructions.
  - Do not connect any load exceeding the contact rating of 30V DC 200 mA.
  - Connect a protection diode (surge absorber) in parallel with inductive loads such as relays to protect the transistor switch from transients when energizing or deenergizing external circuits. (See Figure 3-3).
  - Match the power polarity to the terminal markings when connecting the power supply used to drive the external equipment. (See Figure 3-3).
  - Transistor contacts cannot be used directly to switch (open and close) alternating current (AC) loads. Relays (or similar devices) must be used between the transistor switch and the load. (See Figure 3-4).

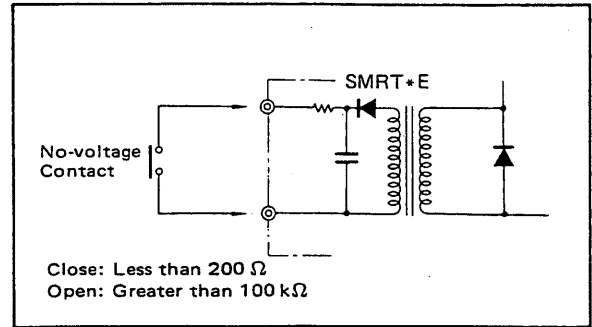

Figure 3-1. External Contact Input Connections.

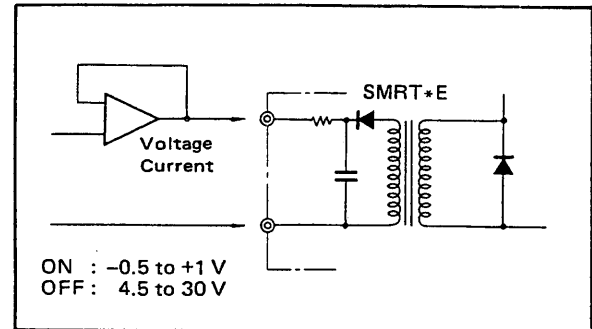

Figure 3-2. Voltage Level Input Connection.

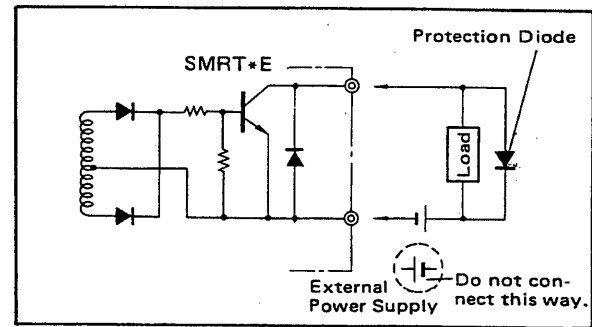

Figure 3-3. Contact Output Connection to External Load.

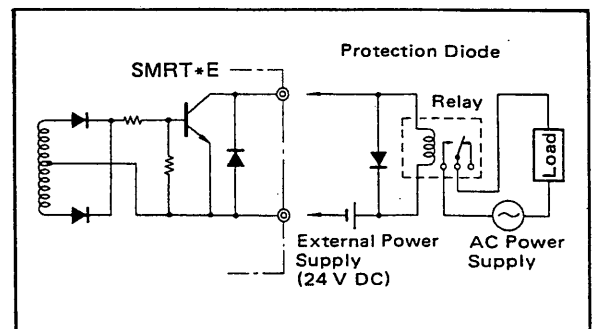

Figure 3-4. Connections for Switching an Alternating Current (AC) Load.

3-3. Terminal Board Wiring.

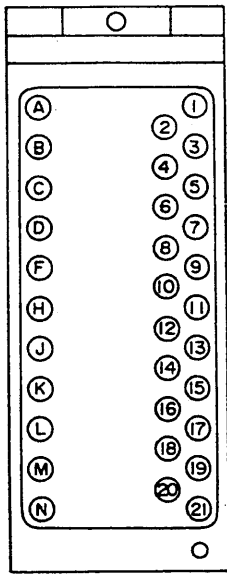

Figure 3-5. Terminal Layout.

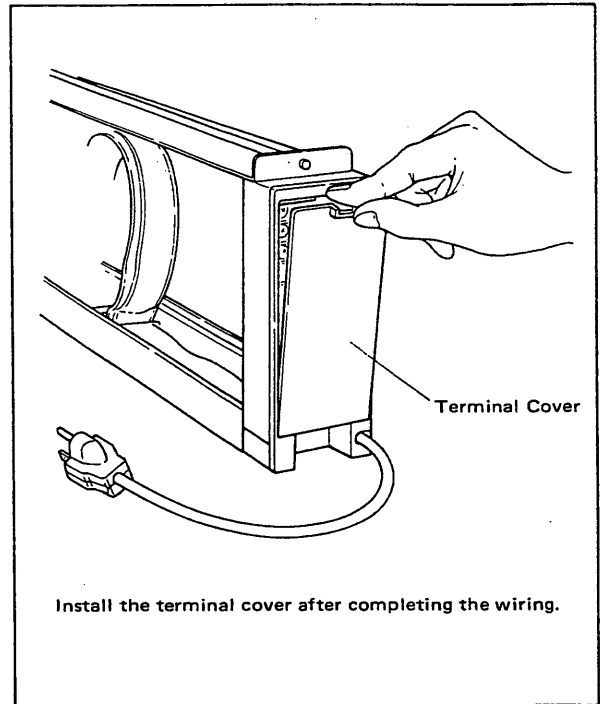

Figure 3-6. Terminal Cover.

TERMINAL CONNECTIONS

Table 3-1.

Terminal Designation	Description	Terminal Designation	Description
1	+ > Process variable input (1 to 5V DC)	17	+ > Communications*1
2	-	18	-
3	+ > Remote ratio set point input (1 to 5V DC)	19	+ > (C, A)/M contact output
4	-	20	-
5	+ > Tracking input (1 to 5V DC)	21	- Fail output (negative terminal)
6	-	A	+ > Manipulated output (4 to 20mA DC)*2
7	+ > External bias input (1 to 5V DC)	B	-
8	-	C	+ > Manipulated output (1 to 5V DC)
9		D	-
10		F	+ > Ratio set point signal output (1 to 5V DC)
11	+ > Mode transfer input	H	-
12	-	J	+ > Process variable high limit alarm output
13	+ > Preset MV input	K	-
14	-	L	+ > Process variable low limit alarm output
15	+ > C/(A, M) Contact output	M	-
16	-	N	+ Fail output (positive terminal)

Notes:

\*1 Use shielded twisted-pair cable (SCCD, see GS 34B5K3-02E).

\*2 Jumper these pins when out of service.

## 4. BASIC OPERATION.

### 4-1. Description of Circuit Operation.

This summary is applicable to the SMRT\*E ratio set station I/O circuit and the signal flow. Refer to this section for the loop wiring and terminal board connections.

Given below are some of the special circuit features for the SMRT\*E ratio set station circuit, a control loop configuration example as well as the I/O circuit and a circuit description.

#### 4-1-1. Circuit Features.

- (1) Since the analog I/O circuit has a high input impedance and a low output impedance, signal transmission errors are virtually nonexistent.
- (2) Since the measurement and other input signals negative lines are common, input bias current has relatively little effect.
- (3) Since the manipulated variable circuit has available both voltage (1 to 5V) and current (4 to 20mA) outputs, they can be used for ratio setting and manipulated output. Moreover, the manipulated current output can be operated during CPU failures.
- (4) Since the power and signal lines are isolated from each other, isolation between loops is preserved.

#### 4-1-2. Control Loop Configuration Example.

Control examples using SMRT\*E are shown in Figures 4-1 and 4-2. Figure 4-1 shows an example of the SMRT\*E used for settings and Figure 4-2 shows the SMRT\*E used to output the manipulated variable. The negative side of the voltage signal line is used as common for the field current signal.

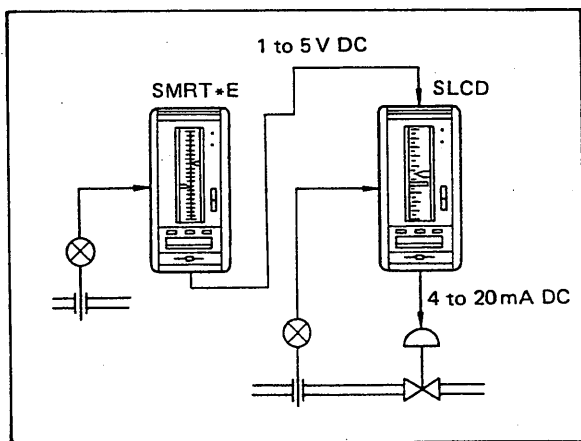

Figure 4-1. Setting Usage Example.

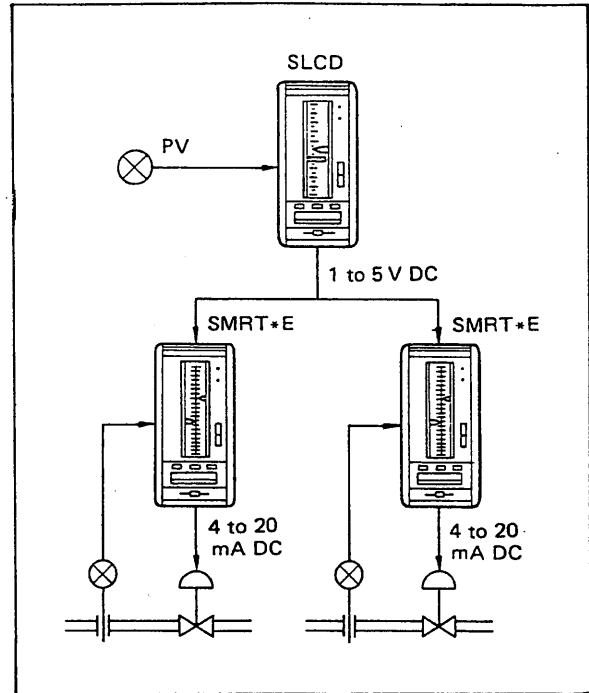

Figure 4-2. Manipulated Signal Usage Example.

#### 4-1-3. Circuit Operation.

Figure 4-3 shows the functional block diagram for the SMRT\*E ratio set station and Figure 4-4 shows the circuit block diagram.

##### (1) Analog input circuit.

A voltage input signal enters the input circuit comprising  $R_{IN}$ ,  $R_1$  and  $C_1$ .  $R_{IN}$  resistance is high (1M ohm), so it normally does not affect circuit operation. If the input circuit is open (input disconnected), however, it provides a DC path between (+) and (-) input terminals to prevent the buildup of static charge on the (+) input line. 0V DC input (e.g. input open) is equivalent to -25% of range.

$R_1$  and  $C_1$  form an input filter of time constant approximately 0.1 sec.

All analog-input negative leads are connected to a common line inside the SMRT\*E.

##### (2) A/D (Analog/Digital) converter circuit.

Analog input signals entering the input circuit are selected in turn by the input multiplexer. The comparator compares an input signal with the output of the D/A (digital/analog) converter circuit, and the CPU adjusts the D/A converter output so that the two signals are equal - basically a successive-approximation type A/D converter. The corresponding digital value is stored in the data memory (RAM).

##### (3) Digital input circuit.

Digital (status) input signals are each isolated by a transformer in the input circuit. Input status is read via an input port and transmitted via the data bus to RAM.

At the same time as the digital inputs are read, the status of switches (C · A · M) on the instrument front and side panels is also read.

(4) Ratio computation circuit.

If the input data is read completely, the microprocessor executes a ratio computation.

The computational result that is obtained is output through the D/A circuit or output ports.

When connected to a supervisory system, data communication is performed via the communication interface (UFCH).

The communication line is optically isolated with a photocoupler.

The WDT (Watch Dog Timer) connected to the CPU monitors the CPU operation and sends a fail contact signal and illuminates the FAIL lamp in the event an abnormal condition occurs.

During a failure, the manipulated current output signal is separated automatically in a digital circuit and can be operated by a manual analog operation. Moreover, the process variable indicator (red pointer) displays the process variable input signal.

(5) Analog output circuit.

The analog output signals, after D/A conversion, are fed via the output multiplexer and buffer amplifier to the current and voltage output circuits.

The analog output signal negative line is common, and is connected directly to the analog input signal common negative line.

(6) Digital output circuit.

Signal from the output ports are transformer-isolated, and are output to the field as open-collector contact signals.

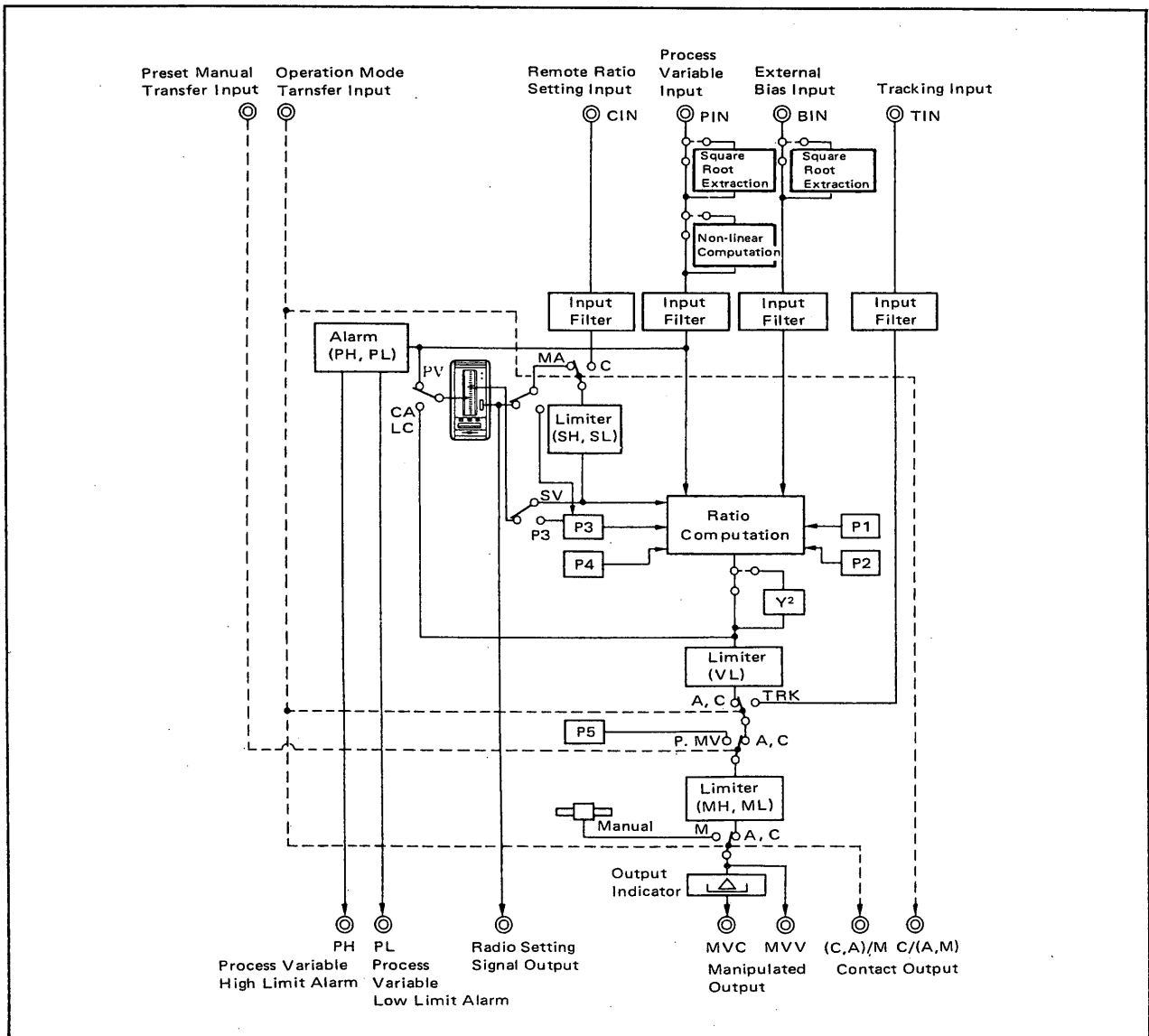

Figure 4-3. SMRT\*E Functional Block Diagram.

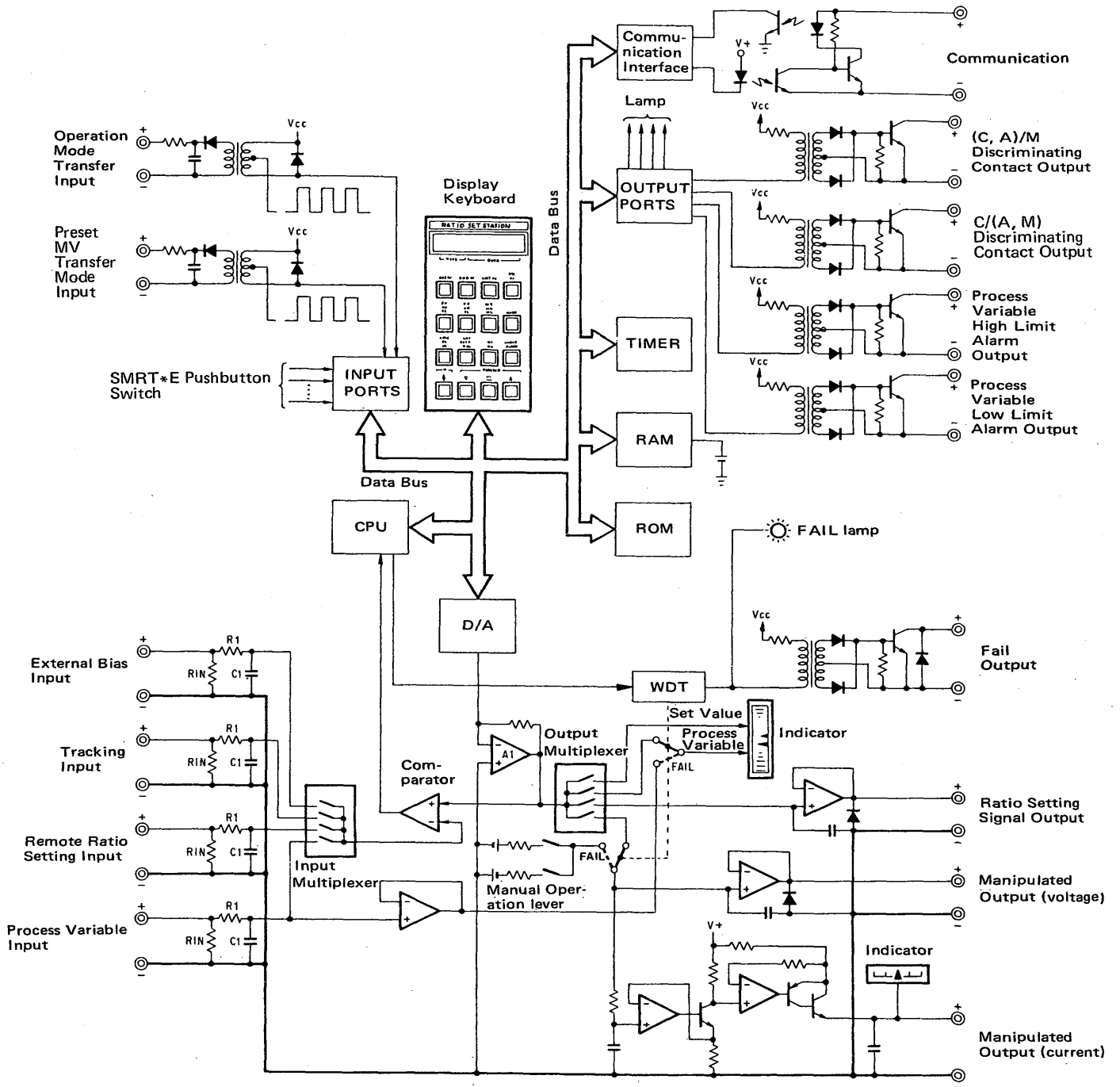

Figure 4-4. SMRT\*E Circuit Block Diagram.



## 5. OPERATION.

### 5-1. Front- and Side-Panel Features.

#### 5-1-1. Station Front Panel.

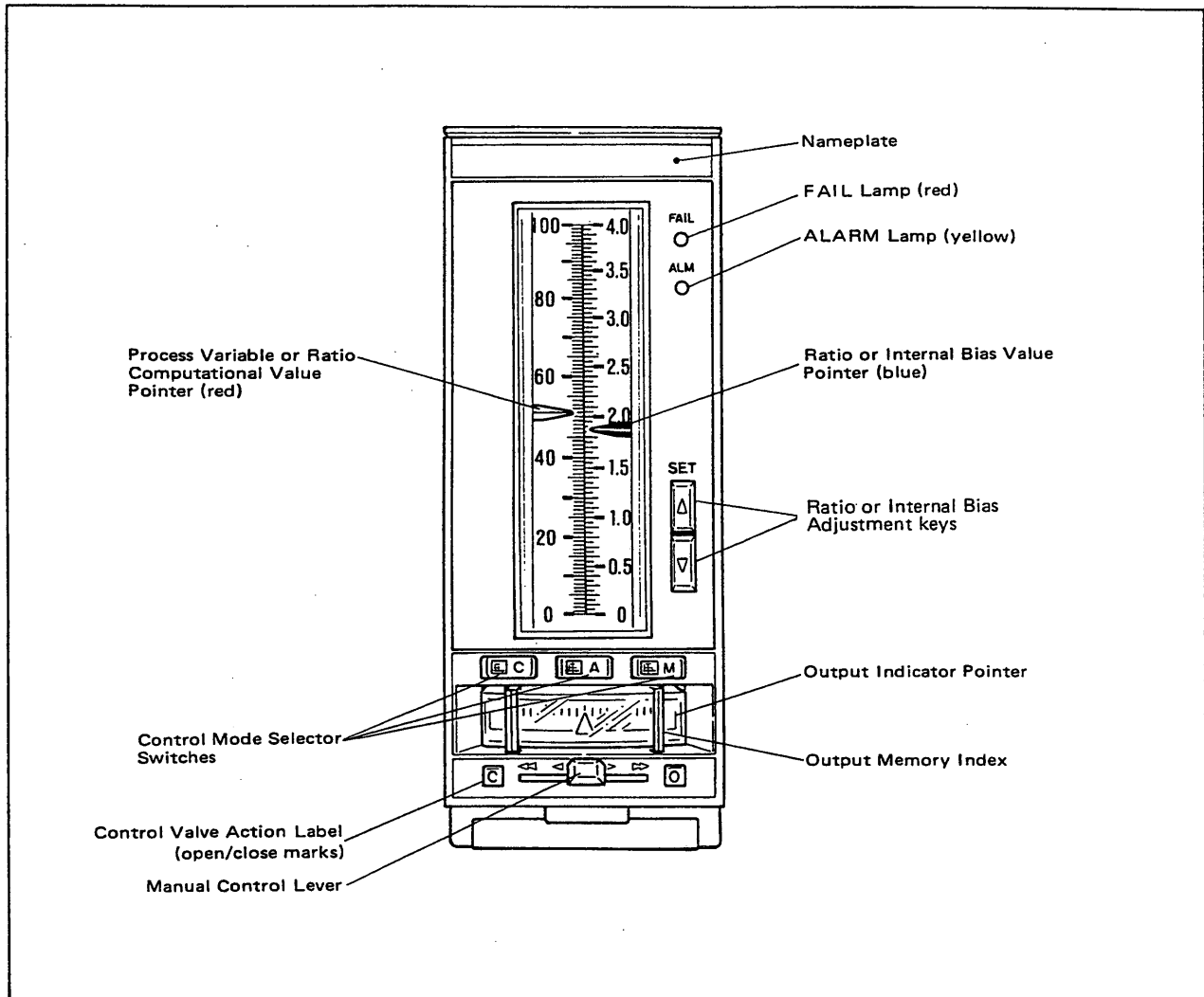

Figure 5-1-1. Front View of Instrument.

- (1) FAIL lamp.  
Lights if an A/D, D/A converter or microprocessor failure occurs.  
With an illuminated indicator, only manual operation is possible.
- (2) ALM lamp.  
Lights to indicate arithmetic range overflow, input signal overrange, current output signal line open or short circuit, or initialized start due to loss of internal data. Refer to section 5-4.  
The lamp flashes when backup battery voltage is low.
- (3) Process variable/ratio computational value pointer indicates the value of the process variable or the ratio computation.
- (4) Ratio/internal bias value pointer indicates the value of the ratio or the internal bias.
- (5) Ratio/internal bias adjustment keys adjust ratio or internal bias value.  
Setting time: 40 seconds/full scale  
Fine adjustment: With a momentary key operation (about 0.2 seconds), the set point moves by 0.1%.



## (6) C/A/M control mode selector switch.

The desired control mode can be selected by pressing the relevant pushbutton.

## Mode C:

Performs a ratio computation with a remote ratio setting signal. In addition, the ratio set point and manipulated output values can be changed from a supervisory computer.

## Mode A:

The ratio can be set from the front panel pushbuttons and the tuning panel so that a ratio computation can be performed.

## Mode M:

This mode permits manual operation. An output operation is performed with the output lever.

## (7) Output indicator.

Shows the current output signal.

Left end of scale reads 4 mA DC.

Right end of scale reads 20 mA DC.

## (8) Manual lever.

Adjusts the manipulated output signal.

Can be adjusted in control mode M.

## Operation:

Moving the lever to the left decreases the signal. Moving the lever to the right increases the signal.

## Rate of change:

◀, ▶ 40 seconds/full scale

◀◀, ▶▶ 4 seconds/full scale

## Fine adjustment:

A momentary (about 0.2 seconds) operation of the lever to the left ◀ or right ▶ changes the control signal by 0.1%.

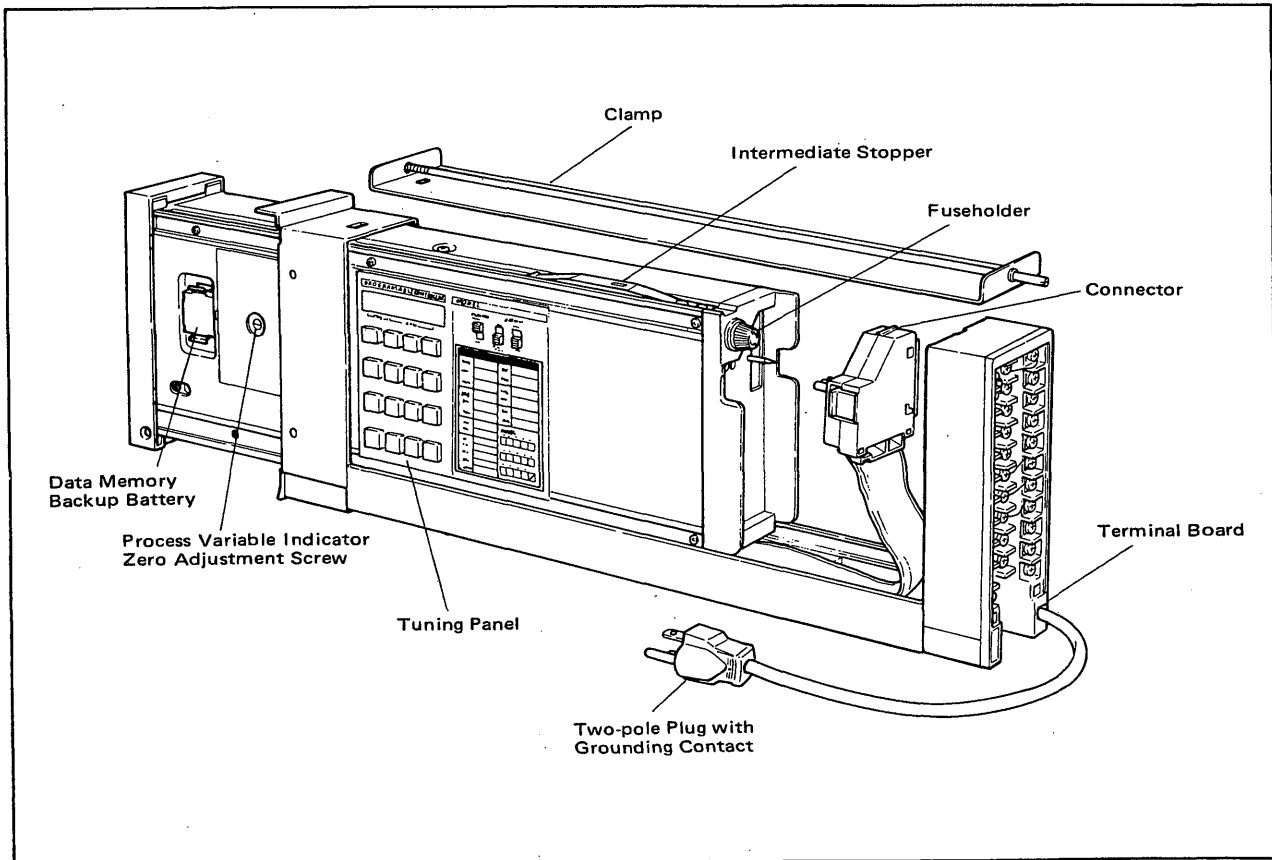

Figure 5-1-2. Side View of Instrument.

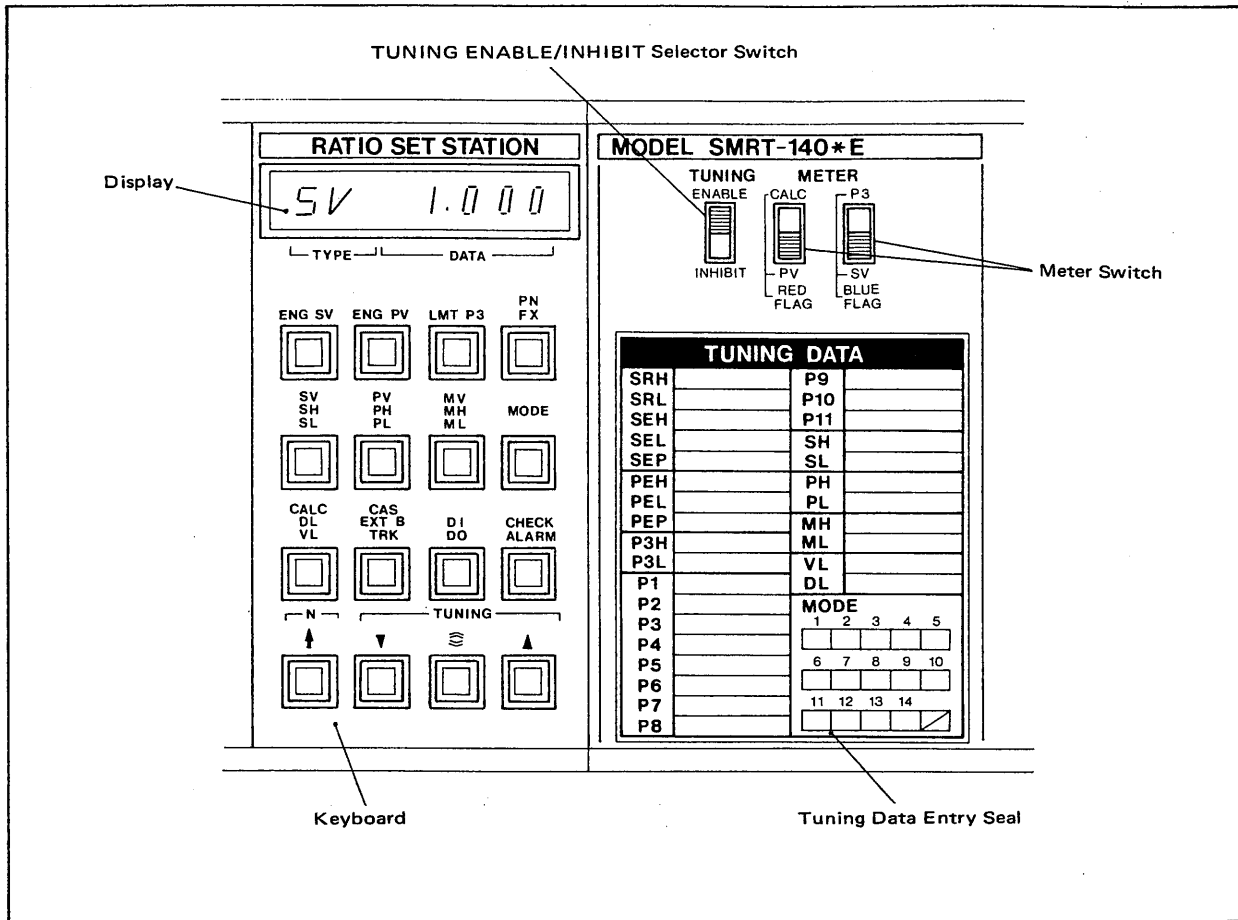

Figure 5-1-3. Tuning Panel.

5-1-2. Tuning Panel Configuration.

Figure 5-1-2 shows the names and functions of the components located on the side panel of the instrument. Parameter setting switches and data monitoring display are provided on the side tuning panel.

(1) Display

Displays the data type code (TYPE) and data value (DATA) for data selected from the keyboard.

[Display example]

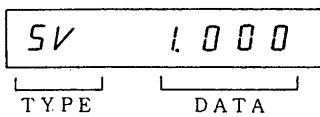

(2) Keyboard

Used for setting parameters, displaying and modifying data and other functions.

(3) TUNING ENABLE/INHIBIT selector switch

Enables or disables the functions of the (▼, ⊞, ▲) pushbutton switches on the tuning panel keyboard.

(4) METER switch

Performs switching for the meter indicator.

PV/CALC:

Selects the process variable input or ratio computation output for display on the indicator (red pointer).

SV/P3:

Selects the ratio or internal bias for display (blue pointer).

(5) Tuning data entry seal.

Each type of setting value, parameter and setting mode are entered in the tuning data label attached to the side panel.

Table 5-1-1. Names and Functions of Tuning Panel Keyboard Switches.

Key	Displayed Name	Content	Range	Units	Settable	Default Value	
ENG. SV	SRH	Internal computational ratio high limit value	0.1 to 8.000	—	○	3.000	
	SRL	Internal computational ratio low limit value	0 to 7.900	—	○	0.300	
	SEH	Engineering unit ratio 100% value	-9999 to 9999	Integer	○	3000	
	SEL	Engineering unit ratio 0% value	-9999 to 9999	Integer	○	300	
	SEP	Decimal point position determination	1 to 4	Integer	○	1	
ENG. PV	PEH	Engineering units 100% value of measurement value indicator graduation	-9999 to 9999	Integer	○	1000	
	PEL	Engineering units 0% value of measurement value indicator graduation	-9999 to 9999	Integer	○	0	
	PEP	Decimal point position determination	1 to 4	Integer	○	3	
LMT. P3	P3H	Internal bias P3 high limit value	-790.0 to 800.0	%	○	100.0	
	P3L	Internal bias P3 low limit value	-800.0 to 790.0	%	○	0.0	
PN	P1	Bias variable corresponding to process variable	-800.0 to 800.0	%	○	0.0	
	P2	Bias variable corresponding to external input	-800.0 to 800.0	%	○	0.0	
	P3	Internal bias variable	-800.0 to 800.0	%	○	0.0	
	P4	Coefficient for external bias	-8.000 to 8.000	—	○	0.000	
	P5	Preset MV value	-6.3 to 106.3	%	○	-6.3	
	P6	Process variable $\sqrt{\quad}$ low input cutoff point	0.0 to 100.0	%	○	1.0	
	P7	External bias $\sqrt{\quad}$ low input cutoff point	0.0 to 100.0	%	○	1.0	
	P8	Process variable LAG time constant	0.0 to 800.0	Sec.	○	0.0	
	P9	Remote ratio input time constant	0.0 to 800.0	Sec.	○	0.0	
	P10	Tracking input time constant	0.0 to 800.0	Sec.	○	0.0	
	P11	External bias time constant	0.0 to 800.0	Sec.	○	0.0	
FX	F01 to 11	Process variable 10 line-segment output set point	0.0 to 100.0	%	○	Linear	
SV	SV	Engineering units ratio set point	Specified by SEH, SEL, SEP	Engineering units	○	0.131 <sup>Note</sup>	
SH	SH	Engineering units ratio high limit value	Specified by SEH, SEL, SEP	ditto	○	3.169	
SL	SL	Engineering units ratio low limit value	Specified by SEH, SEL, SEP	ditto	○	0.131	
	SVN	Internal computational ratio	Specified by SRH, SRL	—	x	—	
PV	PV	Process variable (after square root extraction)	Specified by PEH, PEL, PEP	Engineering units	x	—	
PH	PH	Process variable high limit alarm	ditto	ditto	○	106.3	
	PL	Process variable low limit alarm	ditto	ditto	○	-6.3	
MV	MV	Manipulated output value	-20 to 106.3	%	x (○ in M mode)	-20.0	
MH	MH	Manipulated output high limit value	-6.3 to 106.3	%	○	106.3	
	ML	Manipulated output low limit value	-6.3 to 106.3	%	○	-6.3	
MODE	MODE □	Operation mode (Refer to Table 5-1-2)		Integer	○	0	
CALC	CAL	Ratio computational value	-800.0 to 800.0	%	x	—	
	DL	Ramp constant	Specified by SEH, SEL, SEP	Engineering units/Sec.	○	2.700	
	VL	Output velocity limit	0.0 to 100.0	%/Sec.	○	100.0	
CAS EXT, B TRK	CAS	Remote ratio setting input value (after LAG)	Specified by SEH, SEL, SEP	—	x	—	
	EB	External bias input value (after $\sqrt{\quad}$ , LAG)	Approx. -25.0 to 135.0	%	x	—	
	TRK	Tracking input value (after LAG)	Approx. -25.0 to 135.0	%	x	—	
	PIN	Process variable input	Approx. -25.0 to 135.0	%	x	—	
	CIN	Remote ratio input	Approx. -25.0 to 135.0	%	x	—	
	BIN	External bias input	Approx. -25.0 to 135.0	%	x	—	
DI	D1	Operation mode transfer input	ON: 1, OFF: 0	—	x	—	
	D12	Preset MV transfer input	ON: 1, OFF: 0	—	x	—	
	DO	D01	Process variable high limit value	ON: 1, OFF: 0	—	x	—
		D02	Process variable low limit value	ON: 1, OFF: 0	—	x	—
	D03	(C, A)/M discriminating contact output	ON: 1, OFF: 0	—	x	—	
D04	C/(A, M) discriminating contact output	ON: 1, OFF: 0	—	x	—		
CHECK ALARM	CHECK ALARM	Self-diagnostic result display (Refer to section 5-4-4.)		—	x	—	
		Process alarm (Refer to section 5-4-5.)		—	x	—	
↑	—	Item number change	—	—	—	—	
▼	—	Data decrease setting key	—	—	—	—	
	—	Setting speed-up	—	—	—	—	
▲	—	Data increase setting key	—	—	—	—	

Note: SV value may differ from the default value.

**5-1-3. Explanation of Keyboard Functions.**

Names and functions of keyboard switches are given in Table 5-1-1.

- (1) SRH, SRL: Internal computational ratio high/low limit value.  
SRH, SRL are the internal computational ratios corresponding to the front panel indicator (ratio indicator) 100% and 0% positions respectively. The setting range is 0 to 8.000 and the ratio that is actually in use can be set anywhere in this range. However, the relation  $SRH-SRL \geq 0.100$  must hold.

To set  $SV_n$  in the range 0.300 to 3.000, set  $SRH=3.000$  and  $SRL=0.300$ . Refer to section 5-2-2 paragraph (4) for instructions on setting these parameters.

- (2) SEH, SEL, SEP: 100% and 0% values for engineering unit ratio. SEH, SEL and SEP are data used to specify the indicator scale values for engineering unit ratio SV. They correspond to the 100% and 0% positions on the front panel indicator (ratio indicator). For example, to set the SV scale in the range 0.100 to 0.500, set  $SEH=500$ ,  $SEL=100$  and  $SEP=1$ . (Refer to section 5-2-2 paragraph (4).)

- (3) PEH, PEL, PEP : 100% and 0% values of process variable indicator scale.  
PEH, PEL and PEP are engineering unit values corresponding to the 100% and 0% positions on the front panel indicator (process variable indicator) for reading the process variables in engineering units. For example, when a measurement signal of 0% corresponds to 0.00 m<sup>3</sup>/hr. flow and 100% to 40.00 m<sup>3</sup>/hr. flow, set  $PEH=4000$ ,  $PEL=0$  and  $PEP=2$ . (Refer to section 5-2-2 paragraph (4).)

- (4) P3H, P3L: Internal bias high/low limit value.  
P3H and P3L corresponding to the 100% and 0% positions of front panel indicator (internal bias). P3L and P3H setting range is -800.0 to 800.0% and P3 is set inside the range of P3L to P3H. However, the relationship  $10\% \leq P3H-P3L < 800\%$  must be satisfied.

Moreover, since  $P3H=100\%$  and  $P3L=0\%$  are the initial settings, when the internal bias is 0%, the front panel blue pointer (internal bias indicator) is in the 0% position.

- (5) MH, ML: Output limit.  
A high/low limit check is performed on the ratio computation output and the result is output as the manipulated variable. However, in manual mode these limiters do not operate. If  $ML \leq -6.0\%$  is set, the operation which tightly shuts an output works. When the linear characteristic is required, set it inside the range of -5.9 to 106.3%.

- (6) VL: Velocity limit.  
The velocity limit prevents sudden changes in the ratio computation output from causing large changes in the manipulated output. However, this limit does not operate in M (manual), preset MV and TRK (tracking) modes.

- (7) DL: Ramp constant.  
For balanceless and bumpless transferring of operating modes and ratio setting updates, a ramp constant is provided to avoid sudden output changes. For example, when transferring from M (manual) to A (automatic), the inverse computational result for the engineering unit ratio is set as the initial value and SMRT operates as if the setpoint was being varied. (Refer to Figure 5-1-4.)  
The setting range is engineering unit ratio equivalent to 0 to 100%/sec.

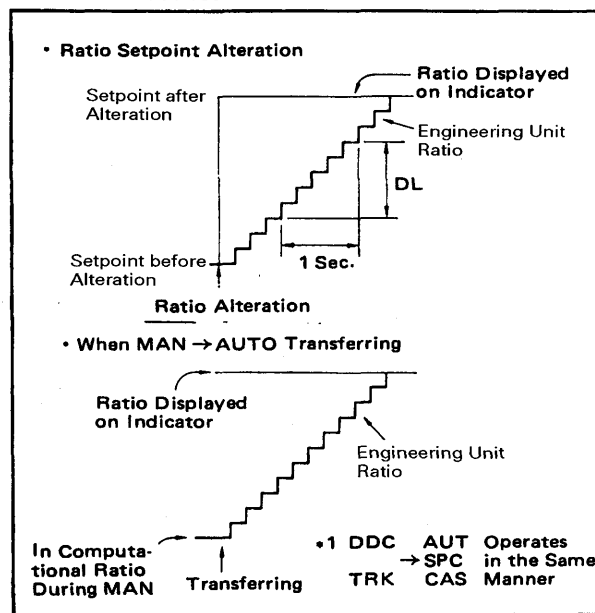

Figure 5-1-4. Ramp Constant.

- (8) CAS: Remote ratio setting input value.  
As described in step (2) above, a remote ratio setting input value of 1V (0%) corresponds to SEL and 5V (100%) corresponds to SEH. An overrange input signal is limited by SL or SH.
- (9) P08 to P11: Time constants for first order lag.  
For each analog input signal, first order lag computation is performed.  
Set each time constant for first order lag within the range of 0 and 800.0sec.

**5-1-4. Operation Mode Functions.**

The operation mode contents and setting states are shown in Table 5-1-2.

- (1) Computational equation (MODE 6)
  - Ⓐ:  $MV = SV_n (PV+P1) + P4 (EB+P2) + P3$
  - Ⓑ:  $MV = SV_n \{ (PV+P1) + P4 (EB+P2) \} + P3$
 Select either equation Ⓐ or Ⓑ above,  
Where:
  - MV = Computational output
  - PV = Process variable input
  - EB = External bias input
  - $SV_n$  = Internal computation ratio
  - P1 = Bias corresponding to process variable input

- P2 = Centering bias for external bias input
- P3 = Internal bias
- P4 = Coefficient corresponding to external bias

Both (A) and (B) are normalized equations.

(2) PV linearization (MODE 8).

Adjustable low cutoff point, square root extraction, and 10-segment line segment function computation can be performed on process variables (PV).

- ① Adjustable low cutoff point, square root extraction.

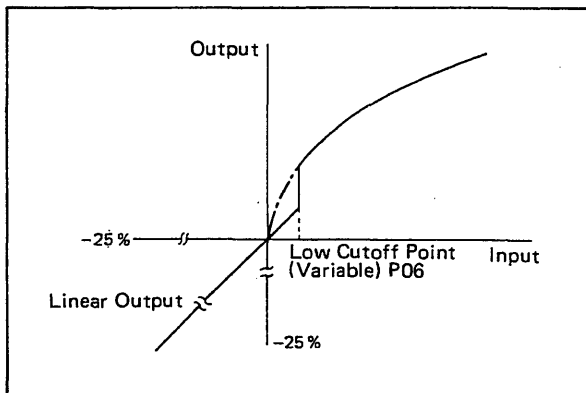

Setting range for low cutoff point is 0 to 100.0 %.

- ② 10-segment line segment function.

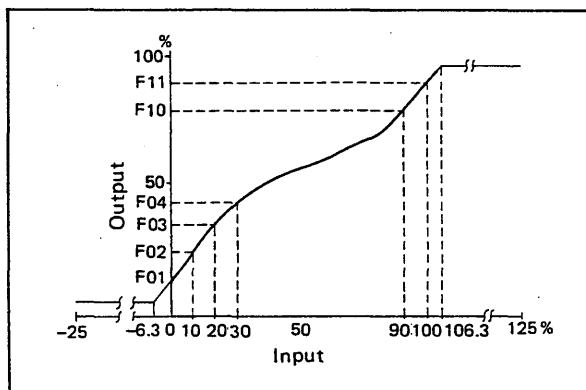

$$-6.3 \leq \text{Input} \leq 0 : \text{Output} = \frac{F02 - F01}{10 - 0} \text{Input}$$

$$-25 \leq \text{Input} \leq -6.3 : \text{Output} = \frac{F02 - F01}{10 - 0} (-6.3)$$

$$100 \leq \text{Input} \leq 106.3 : \text{Output} = \frac{F11 - F10}{100 - 90} \text{Input}$$

$$106.3 \leq \text{Input} \leq 125 : \text{Output} = \frac{F11 - F10}{100 - 90} (106.3)$$

(3) External bias square root extraction (MODE 9).

Adjustable low cutoff point, and square root extraction can be performed on external bias input (EB).

Refer to PV linearization described above.

(4) Bias tracking (MODE 11).

M (manual) to A (automatic) balanceless, bumpless transfer is performed by using a bias. Eventually, an inverse computational result from the current output is used as internal bias P3.

Either (A)' or (B)' is selected automatically by MODE 6.

$$(A)': P3 = MV - SV_n (PV + P1) - P4 (EB + P2)$$

$$(B)': P3 = MV - SV_n \{ (PV + P1) + P4 (EB + P2) \}$$

However, if the computational result does not fall inside the range P3L to P3H, a bump will occur.

(Note) If setpoint tracking is selected (see paragraph (5) below), bias tracking is performed following this operation.

(5) Ratio tracking (MODE 11)

M (manual) to A (automatic) transfer balance operation is performed by using the ratio for a bumpless transfer. The inverse computational result from the current output is then used as the ratio setpoint.

Either (A)'' or (B)'' is selected automatically in MODE 6.

$$(A)'': SV_n = \frac{MV - P4 (EB + P2) - P3}{(PV + P1)}$$

$$(B)'': SV_n = \frac{MV - P3}{(PV + P1) + P4 (EB + P2)}$$

However, if the inverse computational result does not fall inside the range of the ratio setting high/low limits or  $SV_n$  is outside the 0 to 8 range, a bump occurs and the ALM lamp is illuminated.

(Note) If ratio tracking is selected, setpoint tracking (see paragraph (5) below) does not operate.

(6) Setpoint tracking (MODE 12).

With setpoint tracking, the ratio setpoint is in agreement with the remote ratio during M (manual) mode.

Consequently, during M mode the remote ratio setpoint can be displayed on the front indicator.

(Note) If ratio tracking is selected, setpoint tracking does not operate.

(7) Preset MV (MODE 14).

With external status input on or off, the manipulated output value can be switched to a preset MV valve. Data setting range of preset MV valve (P05) is -6.3 to 106.3 %. This switching is only momentary and the output signal do not carry out the ramp following.

Table 5-1-2. Operating Mode (MODE).

Number	MODE content	Data	Setting state
1	Start mode	0	Cold start, manual operation, restarts with a manipulated output value of -6.3%.
		1	HOT start, operation restarts with the status prior to the power failure.
2	C mode	0	During C mode, the remote ratio input value becomes the set point.
		1	During C mode, data transmitted from a supervisory system becomes the set point.
3	External status input transferring mode	0	Operation mode cannot be transferred with the external status input.
		1	(C, A) → M transfer. During C or A operation, external status off selects M mode operation.
		2	C → A transfer. During C operation, external status off selects A mode operation.
		3	TRK, During A or C operation, if an external status input off, output is in accord with the external tracking signal.
4	COMP backup mode	0	During a supervisory system failure, output can be manually transferred to M (manual).
		1	During a supervisory system failure, in the A (automatic) mode set points are maintained and operation can be performed.
5	Communication write	0	Allows operation/settings from supervisory computer.
		1	Inhibits operation/settings from supervisory computer.
6	Computational equation	0	Computes with computational equation (A).
		1	Computes with computational equation (B).
7	External bias	0	No external bias input is used.
		1	External bias input is used.
8	PV Linearization	0	Neither $\sqrt{E}$ nor FX computation for process variable input signal.
		1	$\sqrt{E}$ computation for process variable input signal.
		2	FX computation for process variable input signal.
		3	Both $\sqrt{E}$ and FX computation for process variable input.
9	External bias square root	0	No $\sqrt{E}$ computation for external bias input.
		1	$\sqrt{E}$ computation for external bias input.
10	Output squared	0	Computation output is not squared.
		1	Computation output is squared.
11	Bias tracking Ratio tracking	0	Ratio tracking and bias tracking are not selected.
		1	Bias tracking is selected.
		2	Ratio tracking is selected.
12	Set point tracking	0	Set point tracking is not selected.
		1	Set point tracking is selected.
13	PV alarm contact operating mode	0	Alarm output contact opens during alarm.
		1	Alarm output contact closes during alarm.
14	Preset manual operating mode	0	Preset manual operating mode is inoperable.
		1	Manipulated output can be switched to preset value when contact input is closed (ON).
		2	Manipulated output can be switched to preset value when contact input is open (OFF).

Note) i) All default values are 0.  
 ii) Preset MV is prior to external status input transfer.  
 iii) Preset MV operates in AUT/CAS mode.

5-1-5. Keyboard Operation (See Figure 5-1-6.)

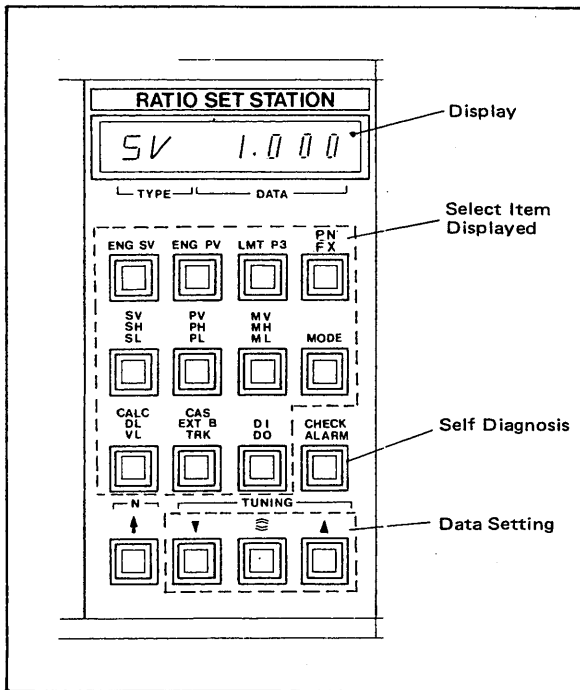

Figure 5-1-6. Functions of Keyboard.

(1) Displaying an item (TYPE)

Press the corresponding key to display the desired data type (TYPE) and its value (DATA).  
If more than one item is assigned to a key the displayed item changes to the next item in order each time the key is pressed.

[Example of key operation and display]

(a) SV/SH/SL key. Each arrow mark indicates the effect of pressing the key once.



(b) ENG/SV key. Each arrow mark indicates the effect of pressing the key once.

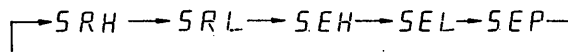

(2) Changing the item number

The item number can be changed by pressing the N key.

[Example of key operation and display]

PN/FX key. Each arrow mark indicates the effect of pressing the key once.

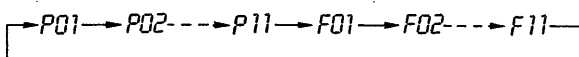

(3) Changing the data value

A data value can be increased or decreased by pressing one of the TUNING keys (down, square wave, up). These switches are active only when the TUNING slide switch is set to enable.

▲ : Data increase setting.

◻ : Sets a higher rate of change.

(Press simultaneously with ▲ or ▼.)

▼ : Data decrease setting.

(4) Self diagnostic

The operating state of the controller can be checked by pressing the CHECK or ALARM key. The method of display is identical to (1) above. (Refer to section 5-4).

5-2. Preparations for Operations.

With the instrument placed on a work station or installed in a panel, prepare the instrument for operation as described below.

Assume that the unit is in the housing. Remove the instrument from the housing as follows:

- (1) Push up on the stopper located below the front panel and draw the unit out. About halfway out the module will contact an intermediate stopper. (See Figure 5-2-1).

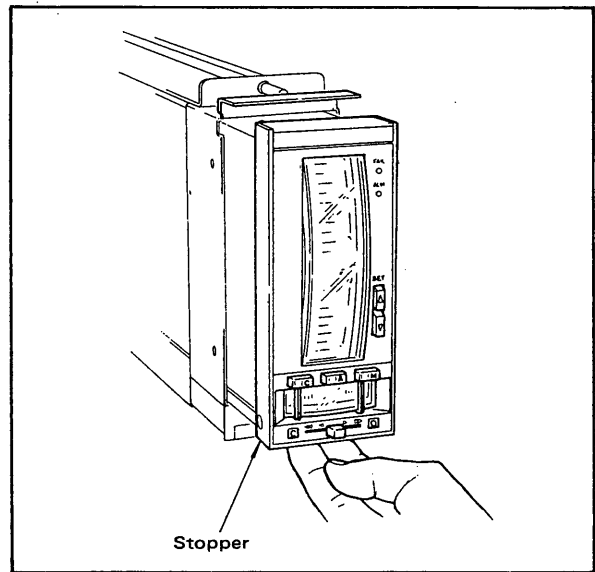

Figure 5-2-1. Removing the Instrument Module.

- (2) To remove the instrument from the housing, push down on the intermediate stopper while pulling the instrument module out of the housing as shown in Figure 5-2-2.

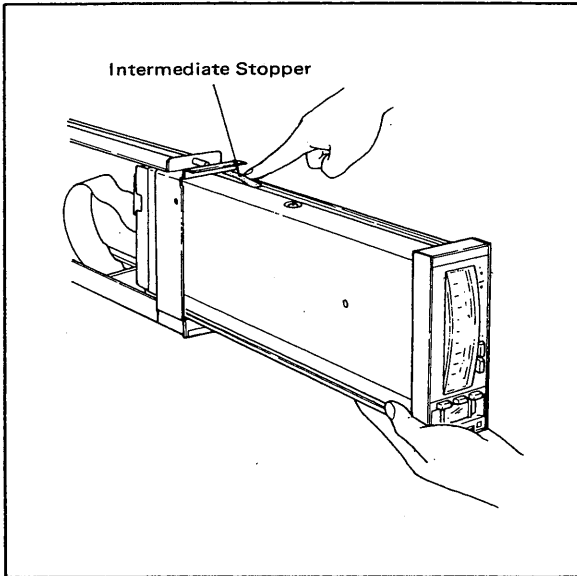

Figure 5-2-2. Removing the Instrument Module.

- (3) Detach the connector from the instrument module. The instrument module is now separated from the housing. (See Figure 5-2-3).

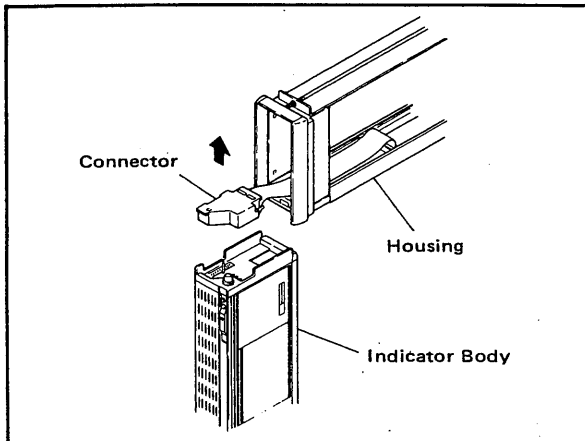

Figure 5-2-3. Detaching the Connector.

**5-2-1. Installing Special Parts.**

Check that the fuse, data memory backup battery and user (application) ROM are installed. If any of these items are not installed, refer to Chapter 6-3 "Parts Replacement" for installation instructions.

**5-2-2. Preparations for Operation.**

- (1) Mounting value action indexes (See Figure 5-2-4). Locate the indexes to match the direct or reverse action of the control value. The indexes can be removed manually or with a pair of tweezers.

- C : Closed (control value closed direction)
- O : Open (control value open direction)

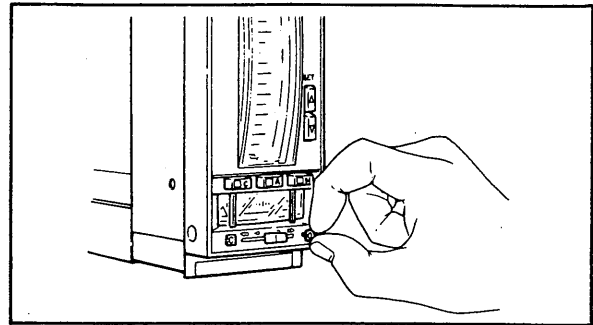

Figure 5-2-4. Mounting Control Valve Action Label.

- (2) Making tuning panel settings  
Set the PV/CALC and SV/P3 selector switches on the tuning panel to the correct positions. Next turn on the power and set the TUNING switch to ENABLE. The parameters can now be set from the keyboard.

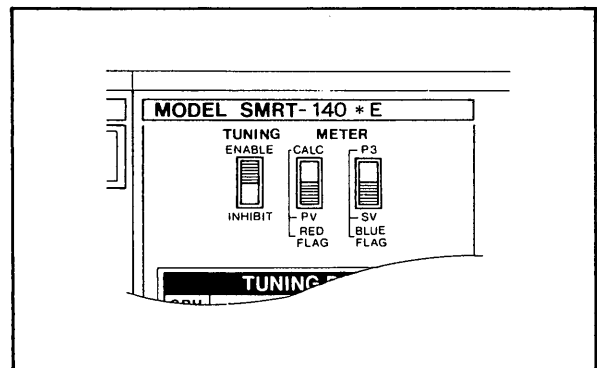

Figure 5-2-5. Setting Selector Switches.

- (3) MODE setting  
Call mode with the MODE key and set the desired mode by pressing ▲ or ▼.  
[Display and setting example]

Pushbutton	Display	Remarks
<input type="checkbox"/> MODE	MODE 1 0	
<input type="checkbox"/> ▲	MODE 1 1	If initial "0" setting is acceptable, advance to the next mode setting.
<input type="checkbox"/> ↑	MODE 2 1	
<input type="checkbox"/> ▼	MODE 2 0	If initial "1" setting is acceptable, go to next setting.
<input type="checkbox"/> ↑	MODE 3 0	
⋮	⋮	

To change mode, keep the ▲ and ▼ keys pressed for approximate one second. (This is required to prevent accidental settings).



(4) ENG. SV setting.

Sets the internal computational ratio high/low limit (SRH/SRL), engineering unit ratio (SV) 100% and 0% values (SEH/SEL) and decimal point position (SEP).

SEH corresponds to the 100% value and SEL corresponds to the 0% value on the scale. Moreover, SEP shows the decimal point position number.

The internal computational ratios corresponding to SEH and SEL are SRH and SRL.

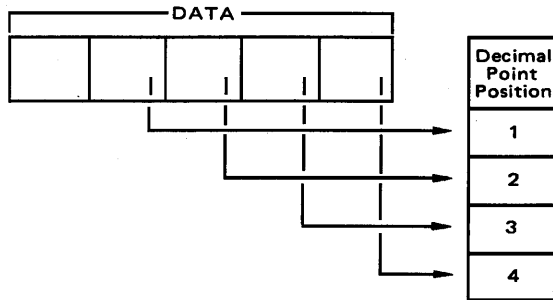

[Example] Use an internal computational ratio range of 0.000 to 0.800 and an engineering unit ratio range of 0.000 to 0.500.

Pushbutton	Display	Remarks
ENG.SV	SRH 3000 L TYPE J L DATA J	The present SRH value is displayed in the DATA area.
▼	SRH 0800	Can be used simultaneously with  key.
ENG.SV	SRL 0.300	The present SRL value is displayed in the DATA area.
▼	SRL 0.000	Can be used simultaneously with  key.
ENG.SV	SEH 3000	The present SEH value is displayed in the DATA area.
▼	SEH 500	Can be used simultaneously with  key.
ENG.SV	SEL 300	The present SEL value is displayed in the DATA area.
▼	SEL 0	Can be used simultaneously with  key.
ENG.SV	SEP 1	The present SEP value is displayed in the DATA area. For details on decimal point position, refer to the figure above. However, if setting changes are required, use the ,  keys.

Moreover, ENG. PV settings are performed in the same manner as SEH, SEL and SEP above. For example, when setting engineering unit flow rate ranges of 0.0 m<sup>3</sup>/hr to 100.0 m<sup>3</sup>/hr, set PEH=1000, PEL=0 and PEP=3.

(5) SV, SH and SL settings.

Inside the SEL to SEH range set in (4) ENG.SV above, set engineering unit ratio (SV), and ratio setting high/low limits (SH, SL).

However, when SH and SL are not set, the ratio setting limits are set to their initialized values.

[Example] Set SV=0.200, SH=0.450 and SL=0.100 using an engineering unit ratio range of 0.000 to 0.500. After setting SEH=500, SEL=0 and SEP=1, follow the procedure below to set them.

Pushbutton	Display	Remarks
SV	SV 0.000 L TYPE J L DATA J	The present SV value is displayed in the DATA area.
	SV 0.200	Can be used simultaneously with  key.
SH	SH 0.500 L TYPE J L DATA J	The present SH value is displayed in the DATA area.
	SH 0.450	Can be used simultaneously with  key.
SL	SL 0.000 L TYPE J L DATA J	The present SL value is displayed in the DATA area.
	SL 0.100	Can be used simultaneously with  key.

(Note) The decimal point position is determined by the SEP setting. Moreover, PH, PL, MH, ML, P3H, P3L, VL and DL are set in the same manner.

(6) Setting other parameters

Set all parameters necessary for control and computation. It is convenient to write the setting parameters in the spaces provided on the sidepanel label.

[Parameter setting example]

Setting the internal bias P3 to 10.0%.

Pushbutton	Display	Remarks
PN	P1 0.0	The present P1 value is displayed in the DATA area.
N	P2 0.0	The present P2 value is displayed in the DATA area.
N	P3 0.0 L TYPE J L DATA J	The present P3 value is displayed in the DATA area.
	P3 10.0	Can be used simultaneously with  key.

(Note) After selecting computational equation or , set all unnecessary parameters to zero.

(7) Data that can be monitored

See Table 5-1-1 "Names and Functions of Tuning Panel Keyboard Switches".

(8) Inclined mounting

When the indicator is mounted at an angle from the vertical, the indicator zero adjustment must be recalibrated. Refer to item 6.2 for the correct calibration procedure.

After completing all the necessary preparations, disconnect the power plug, install the instrument in the panel, connect the I/O signal wires and finally connect the power supply.

### 5-3. Startup and Operation.

#### 5-3-1. Manual Startup.

- (1) Manual operation with manual control lever
  - (a) From the C/A/M selector switches, select **M**. (The lamp inside the pushbutton lights, see Figure 5-3-1.)

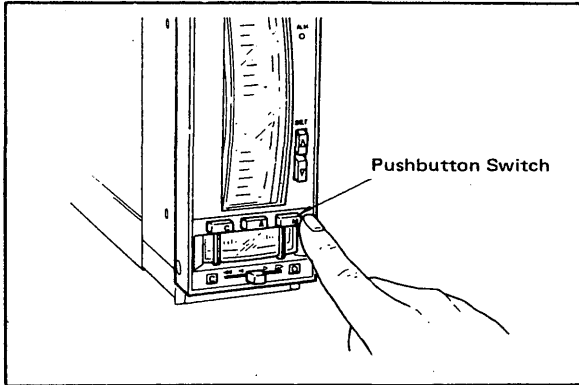

Figure 5-3-1. Selecting the Control Mode.

- (b) Move the manual control lever left (or right) to adjust the output level. (Refer to Figure 5-2-2.)

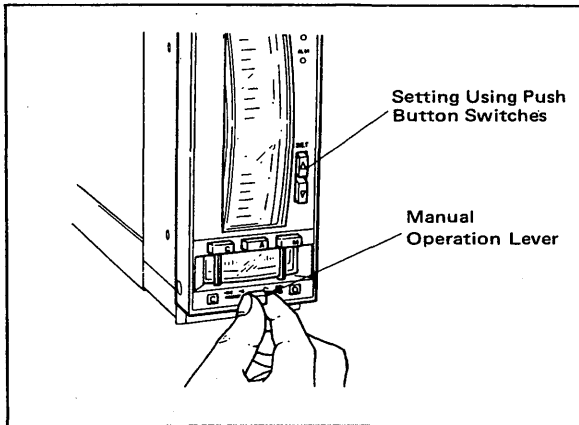

Figure 5-3-2. Manual Control of Output.

- (c) Set the desired value using the SET pushbutton switches. (Refer to Figure 5-3-5.)

#### 5-3-2. Alarm Check and Transfer to Automatic Operation.

- (1) Alarm check (See Figure 5-3-3).  
When the ALM lamp on the front panel is illuminated, it indicates that some signal failure occurred. Use **CHECK** and **ALARM** on the side tuning panel to diagnose and correct the failure. If the FAIL lamp is on, there is some problem in the ratio set station itself. Refer to section 5-5.
- (2) Transferring from manual to automatic operation  
Depress in the **C** **A** **M** control mode selector switches marked **A**. The lamp in switch **A** illuminates and the station transfers to automatic.

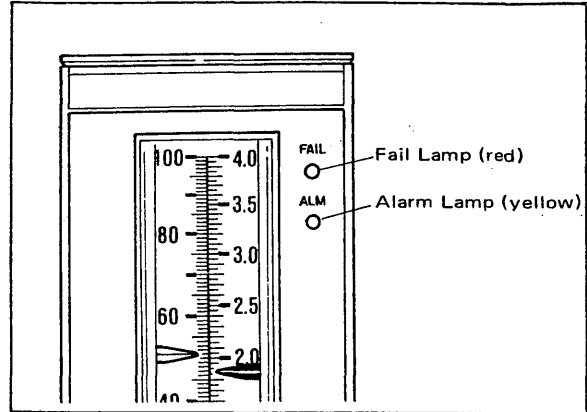

Figure 5-3-3. Fail and Alarm Lamps.

#### 5-3-3. Normal Operation.

- (1) Transferring between operating modes  
The operating mode of the station can be freely changed by depressing the **C**, **A** or **M** pushbutton switches. (See Figure 5-3-1). (However, note that direct transfers from **M** to **C** mode are not allowed.)
- (2) Parameters setting on the tuning panel  
If parameters must be altered, remove the unit from its housing and set or alter the parameters on the tuning panel. After completing the setting operation, turn the TUNING switch back to the INHIBIT position to prevent accidental parameter changes.

#### 5-4. Action to be Taken when FAIL or ALM Lamps Light.

Any faults in this unit or in the signal connections are shown by illuminated FAIL or ALM indicators. If either of these indicators illuminate or flash, immediately take appropriate action as described below.

##### 5-4-1. Action when FAIL Lamp Lights.

An illuminated FAIL lamp signifies that a serious error has occurred.

- (1) Monitor the current output signal and set it at a safe level using the manual control lever.  
(In FAIL status, the current output can be directly controlled by the manual control lever. The value of the analog and digital output signals depends on the type of fault.)  
At this time, the process variable indicator (red pointer) indicates the value of the process variable input signal (between terminals 1 and 2)
- (2) By inserting the connecting cable from the standby manual station SPBD into the jack in the low area of the housing, switch the output signal from the SMRT\*E to the SPBD.
- (3) Select the CHECK item on the front tuning panel and examine the basic cause of the error. (Refer to section 5-4-4).

**5-4-2. Action when the ALM Lamp Lights.**

The ALM lamp lights if the high or low limit alarms of the station operate, or when input-output signals are disconnected.

Select the "CHECK" item and "ALARM" item on the tuning panel, and display the cause of failure. (Refer to 5-4-4 and 5-4-5.)

Take appropriate measures corresponding to the cause of the fault.

**5-4-3. Action when ALM Lamp Flashing.**

If the data backup battery voltage is low, the alarm lamp begins to flash. The battery should be replaced (refer to section 6.3.4 for the replacement procedure).

Notes:

- (1) If the ALM lamp begins to flash during normal operation, replace the battery within one month.
- (2) The flashing of the ALM lamp has precedence over its continuous lighting. Thus, other alarms cannot be displayed while the lamp is flashing. (But other alarms can still be displayed on the tuning panel display.)

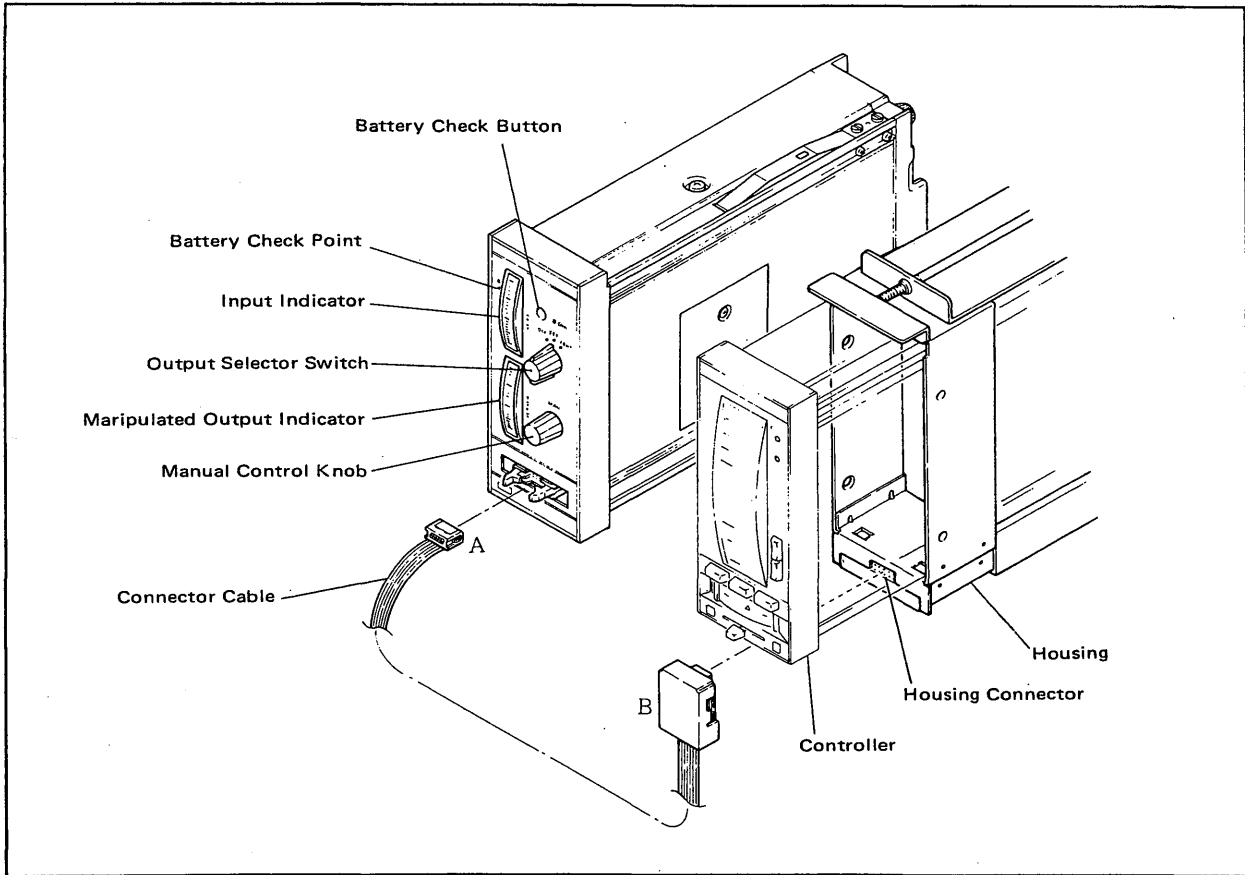

**Figure 5-4-1. Connecting to the Controller Housing Connector.**

**5-4-4. CHECK Display.**

The CHECK display items are listed below.

Lamp	CHECK display	Diagnosis
—	00	Normal.
FAIL	01	Fault in A/D converter.
FAIL	02	Fault in D/A converter.
ALM	04	Arithmetic range overflow.
ALM	08	Input overrange.
ALM	20	Data memory backup battery not installed, or (lamp flashing) low battery voltage.
ALM	40	Current output signal line open or short circuit.
FAIL	80	RAM memory data lost.
ALM	PWR ERR	Supply voltage too low.
FAIL	—	Instrument fails. (A display is impossible.)

Since the set parameters are initialized when CHECK=80 is displayed and the ALM lamp is illuminated, set all the set points again on the side panel.

If two or more faults occur at the same time, the displayed value is the total of the individual display values (sum of the hexadecimal numbers).

[Examples]

CHECK 0C

0C = 04 + 08 (arithmetic range overflow, input overrange).

CHECK A0

A0 = 20 + 80 (battery voltage low, data lost)

The displayed value returns to 00 when basic cause of the fault is removed.

However, display 80 (lost internal data) does not return automatically to 00.

The  key must be used to set the display to 00.

**5-4-5. ALARM Display.**

The ALARM display items are listed below.

Lamp	ALARM display	Diagnosis
—	00	Normal.
ALM	01	PV high limit alarm.
ALM	02	PV low limit alarm.
ALM	04	SV high limit alarm.
ALM	08	SV low limit alarm.

If two or more alarms occur at the same time, the displayed value is the total of the individual values (sum of hexadecimal values).

[Example]

ALARM 06

06 = 02 + 04 (process variable low limit plus ratio setting high limit alarm)

The displayed value reverts to zero when the basic cause of the alarm is removed.



## 6. MAINTENANCE.

The chapter explains relatively simple instrument calibrations and parts replacement procedures.

### 6-1. Equipment Required for Calibration.

Standard DC voltage source:

Yokogawa's type 7651 or equivalent.

Digital multimeter:

Yokogawa's type 7562 or equivalent.

### 6-2. Indicator Inspection and Calibration.

#### 6-2-1. Process Variable Pointer Zero Adjustment.

The side-panel slide switch is used to set PV.

- (1) Apply 3.0V DC from a standard voltage source between input terminals 1 (+) and 2 (-). Refer to section 3-1-2.
- (2) Confirm that the process variable pointer is at the  $50\% \pm 0.5\%$  calibration mark on the scale.
- (3) If the indication is not within the specified range, adjust the zero adjustment screw as shown in Figure 6-2-1 until the pointer correctly indicates 50%.
- (4) Set the input signal alternately to 1.0V, 2.0V, 4.0V and 5.0V and ensure that the indicator respectively reads the 0%, 25%, 75% and 100% points using the calibration marks. Allowable tolerance is  $\pm 0.5\%$  of span.  
Check each calibration mark at the position where line of sight and set point value indicator are horizontal.
- (5) If the indicator is not within the 0.5% tolerance at any of the calibration points in step 4 above, input 3.0V DC again and adjust the indicated value slightly within the range  $50\% \pm 0.5\%$ .
- (6) Repeat step 4 above. Repeat steps 4 and 5 until all points fall within tolerance.

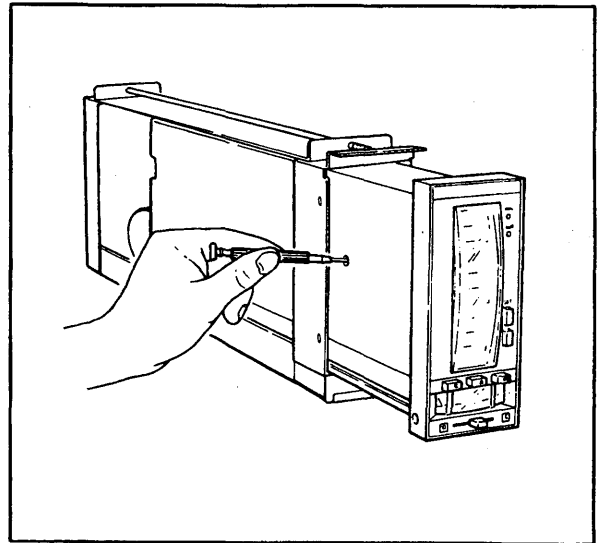

Figure 6-2-1. Zero Adjustment for Process Variable Indicator.

#### 6-2-2. Adjusting the Setting Indicator Zero.

Set slide switch on the side panel to SV and select  mode.

- (1) Apply a 3V DC standard voltage to input terminals 3 (+) and 4(-) from a standard voltage source.

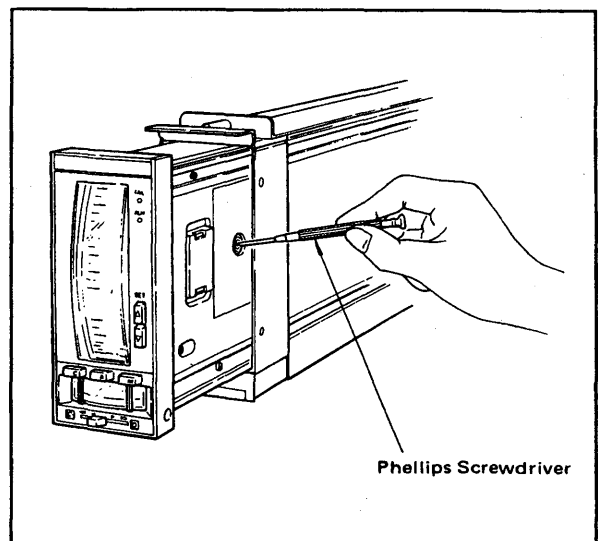

Figure 6-2-2. Zero Adjustment for Set Value Indicator.

- (2) Adjust using the same procedure as described in steps (2) thru (6) for the process variable indicator (6-2-1). Figure 6-2-2 shows zero point adjustment for set value indicator.

### 6-2-3. Manipulated Output Indicator Zero Adjustment.

- (1) Connect an ammeter (7562) across current output terminals A (+) and B (-) (refer to section 3-1-2). Insure that the unit is in **M** mode.
- (2) Set the output indicator exactly in the center of the scale. Confirm that this setting produces an output of 12 mA. (allowable tolerance is  $\pm 2.5\%$ ) Check each major scale graduation at the position where line of sight and output pointer are vertical.

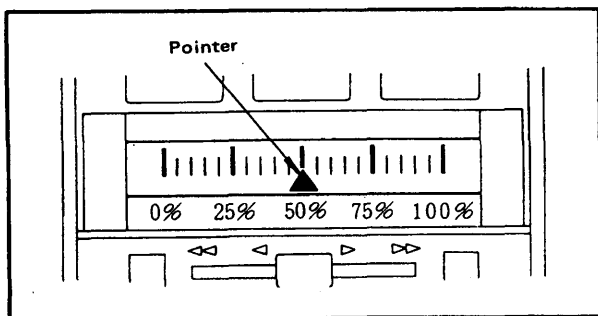

Figure 6-2-3. Output Indicator Center Scale Mark.

- (3) If necessary, adjust the indicated value with the zero adjustment shown in Figure 6-2-4.
- (4) Set the pointer to the 0%, 25%, 75% and 100% major graduation points on the scale. Insure that the output current is 4 mA, 8 mA, 16 mA and 20 mA respectively at these points (allowable tolerance  $\pm 2.5\%$ )
- (5) If any of the points in step (4) is out-of-tolerance, repeat step (2) and adjust the zero adjustment while keeping the indicated value within the allowable tolerance.
- (6) Repeat step 4. Repeat steps 4 and 5 until every major graduation point falls within tolerance.

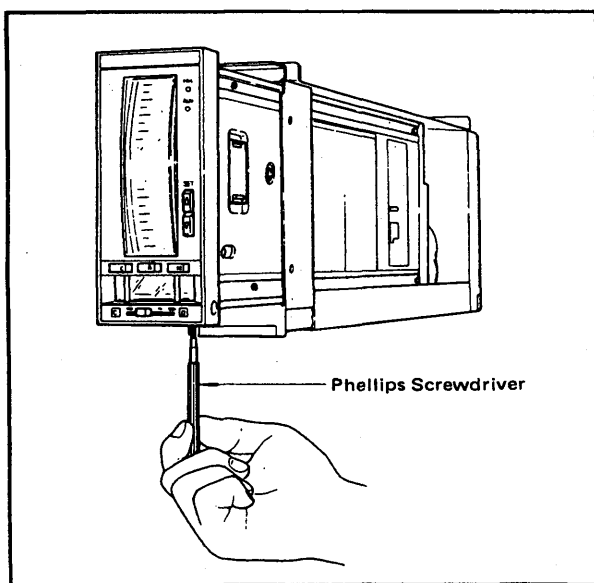

Figure 6-2-4. Zero Adjustment for Output Indicator.

### 6-2-4. Inclined Mounting.

If the instrument is to be mounted at an angle, adjust the process variable indicator (6-2-1) and set value indicator (6-2-2) with the instrument mounted at the actual mounting angle.

## 6-3. Parts Replacement.

### 6-3-1. Replacing Nameplate.

Draw the instrument module out a short distance and open the lid located on the top of the front panel. Remove the nameplate and install a new one. (See Figure 6-3-1).

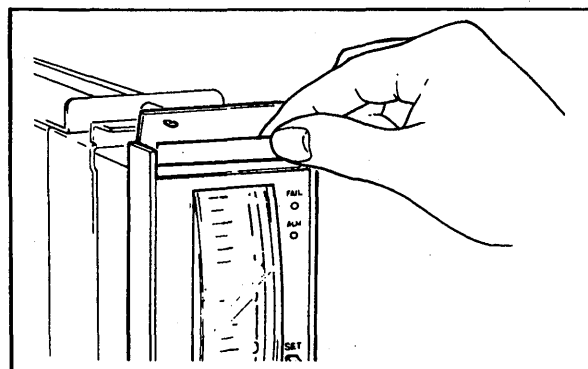

Figure 6-3-1. Replacing Nameplate.

### 6-3-2. Replacing Scale Plate.

Open the lid on the top of the front panel with the instrument module pulled out a short distance. Remove the press-fit retaining cap using a small regular screwdriver. To remove the scale, grasp the upper end of the scale with a pair of tweezers and pull the scale out. Insert a new scale plate and replace the cap.

[Removing the scale plate]

- Contact the engraved face and rear of the scale plate as little as possible when removing the scale plate.
- To clean a scale plate, lightly rub the plate with a soft cloth or suitable equivalent (do not use alcohol or other solvents as they can separate the markings from the scale plate).

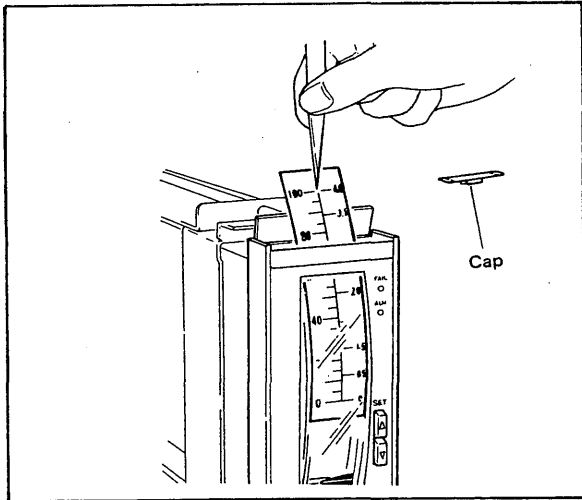

Figure 6-3-2. Replacing Scale Plate.

**6-3-3. Replacing Fuse.**

If a problem seems to be associated with the fuse itself, inspect the inside of the fuse holder for contamination or poor contact.

Recommended fuse replacement interval: 3 years

- (1) To remove the fuse, unscrew the fuse holder cap in the direction of the arrow on the cap. The cap and fuse can then be removed.
- (2) Install a new fuse with the correct rating. Replace the fuse cap securely.

Note: Use the dedicated fuse (S9510VK). Do not use a fuse for other products.

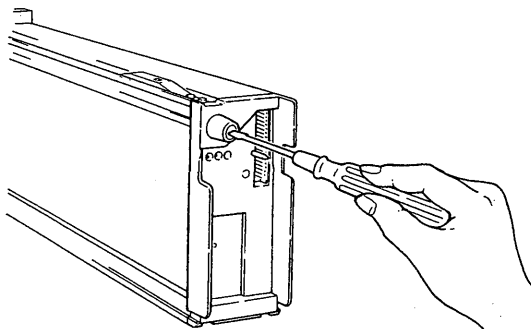

Fuse Part No.: S9510VK  
Rating : 1 A

Figure 6-3-3. Replacing Fuse.

**6-3-4. Replacing Data Memory Backup Battery.**

Note 1: The power should be turned on to the unit while the battery is being replaced. If the battery is changed with the power off, the memory data will be lost.

Recommended replacement intervals:

About 5 years (charging, at ambient temperatures below 45°C)

About 1 year (shelf-life, at ambient temperatures below 45°C)

- (1) Draw the ratio set station module out a short distance from the housing and remove the battery cover and the battery. (See Figure 6-3-4).

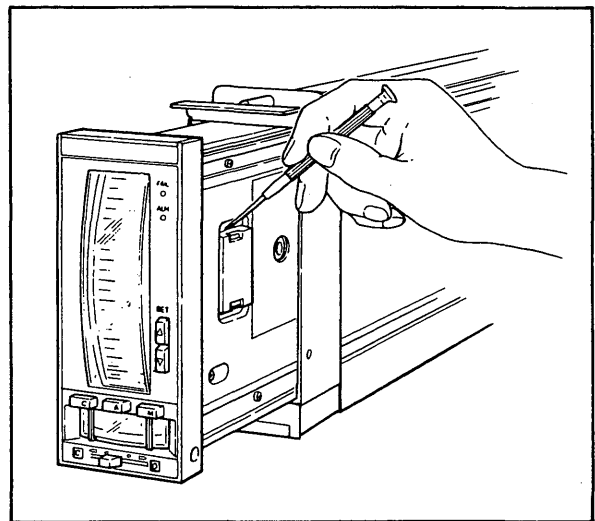

Figure 6-3-4. Removing Battery Cover.

- (2) Install a new battery and fit the battery cover securely in place. (See Figure 6-3-5).

- (3) Insure that the ALM lamp has stopped flashing.

Note 2: Do not change just the battery itself. Always replace the case and battery at the same time.

Note 3: Use a high impedance voltmeter to measure the battery voltage.

Note 4: When placing the new battery in the battery case after removing the old battery, be sure to observe correct battery polarity.



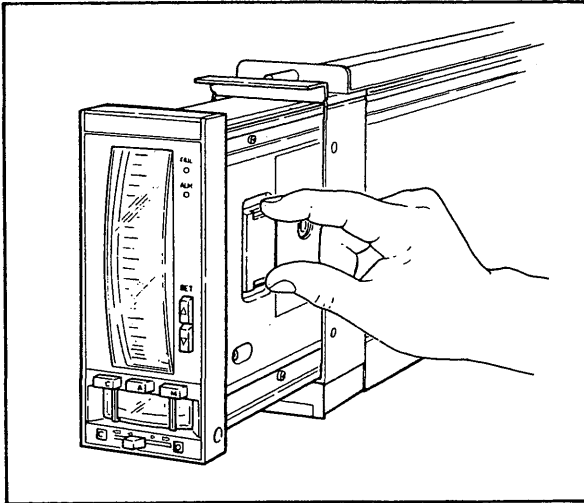

**Figure 6-3-5. Replacing Data Backup Battery.**

---

**Precautions For Data Backup Battery Installation and Storage**

---

- (1) Ambient Temperature:  $-10$  to  $60^{\circ}\text{C}$   
Ambient Humidity: 5 to 95% (noncondensing)  
Location free from corrosive gases.
- (2) Do not charge the battery.
- (3) Do not place the battery in a fire.
- (4) Do not short together the positive and negative poles of the battery.
- (5) Refrain from heating or attempting to disassemble the battery.
- (6) Carefully observe correct polarity when connecting the battery wires.

# Customer Maintenance Parts List

Model SMRT (Style E)  
Ratio Set Station

YEW SERIES 80

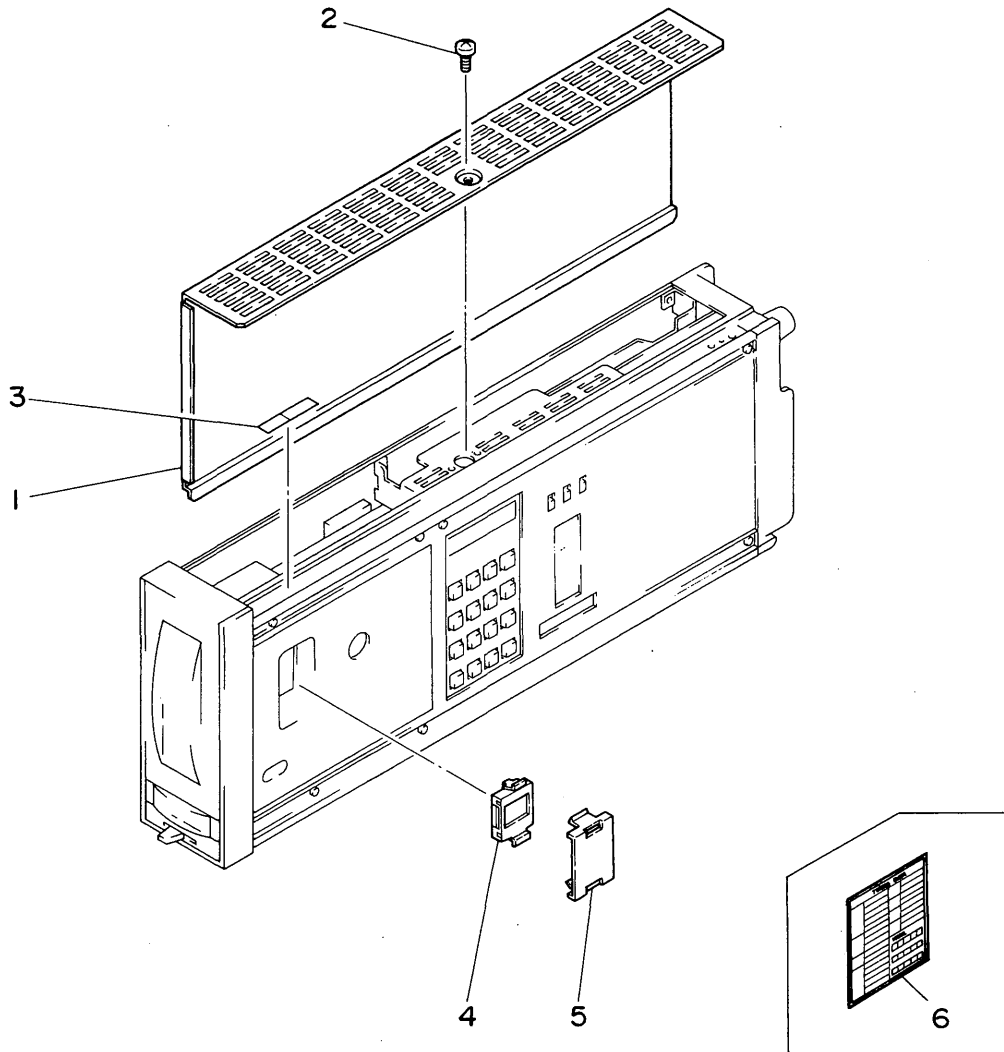

Item	Part No.	Qty	Description
1	E9711TG	1	Cover
2	Y9405LB	1	B.H. Screw, M4 x 5
3	Y9422NP	1	Tag No. Label (blank)
4	E9711DH	1	Battery Assembly
5	E9711GQ	1	Cover
6	E9714DZ	2	Data Label

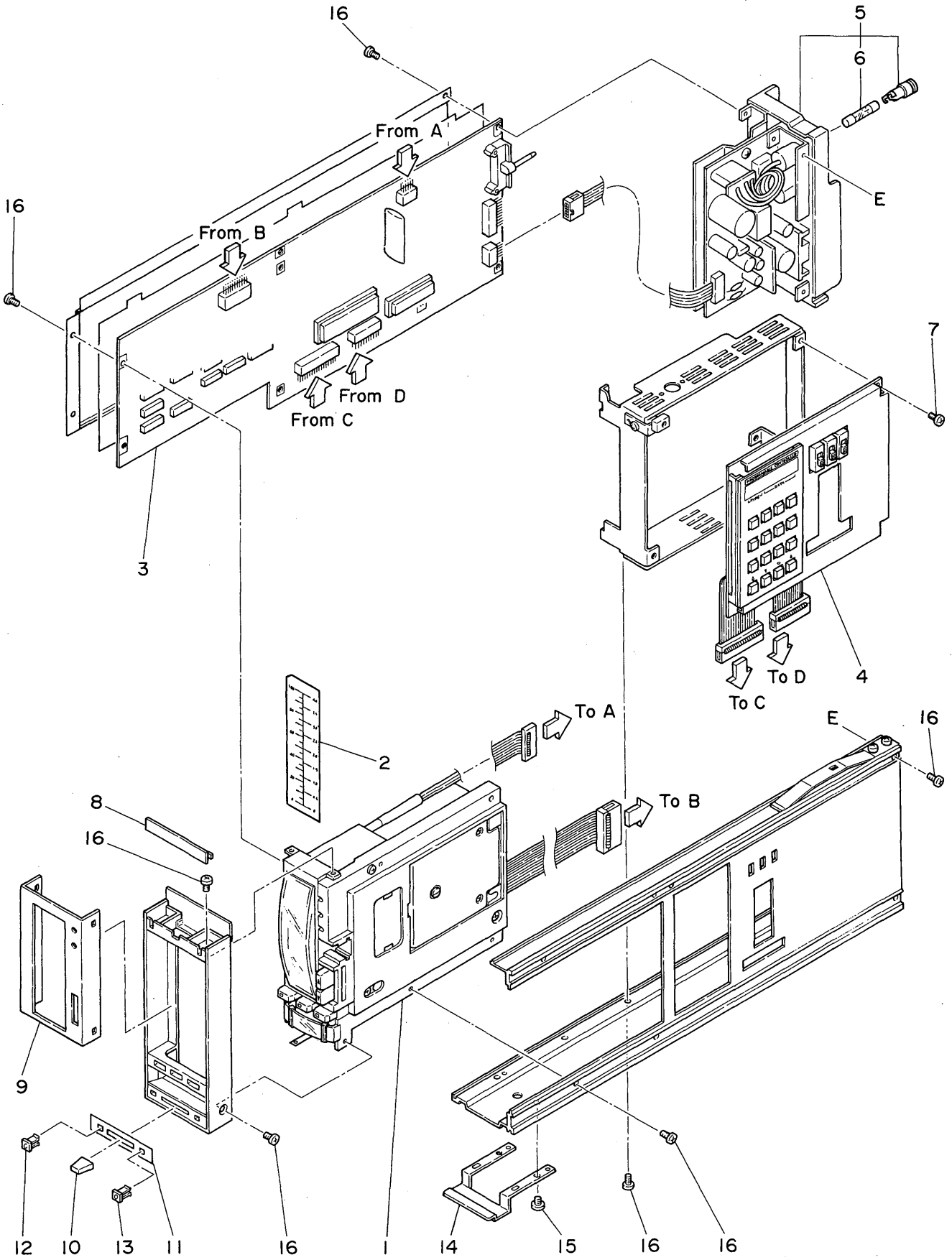

Item	Part No.	Qty	Description
1	E9714AJ	1	Meter Assembly (see page 4)
2	—	1	Scale (specify range when ordering)
—	—	1	Control Assembly
3	E9714LD	1	I/O Board Assembly
4	E9714FD	1	CPU Board Assembly
5	Below	1	Power Supply Unit
	E9716YB		For 100 V Version
	E9716YS		For 220 V Version
6	S9510VK	1	Fuse — "1A"
7	Y9306JB	9	Pan H. Screw, M3 x 6
8	E9711FG	1	Plate (blank)
9	E9711HA	1	Bracket
10	E9711KA	1	Knob
11	E9711KE	1	Plate
12	E9711KC	1	Tip — "C"
13	E9711KD	1	Tip — "O"
14	E9711TD	1	Stopper
15	E9711TE	2	Screw
16	Y9306JB	14	Pan H. Screw, M3 x 6

### E9714AJ Meter Assembly

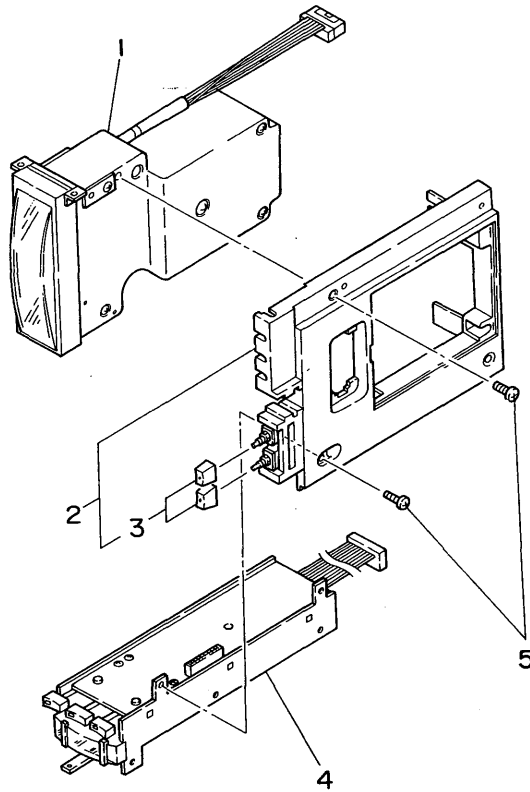

Item	Part No.	Qty	Description
1	E9714AK	1	Meter Assembly
2	E9711DA	1	Frame Assembly
3	E9711FH	2	Knob
4	E9711KM	1	A/M Unit
5	Y9306JB	5	Pan H. Screw, M3 x 6

# Instruction Manual

## / HTB Power Supply Terminal Connections for Panel - mounted Instruments (Option)

### 1. GENERAL.

If you specify the terminal board to which the power source is directly connected (suffix code / HTB), the external wiring to the terminal board is necessary.

### 2. APPLICABLE INSTRUMENTS.

Model	Description
SRVD	Strip Chart Recorder
SIHM	Indicator (With Housing)
SIHF	Bar Graph Indicator (With Alarms)
SIHK	Indicator (With Alarms)
SLCD	Indicating Controller
SLPC	Programmable Indicating Controller
SLMC	Programmable Indicating Controller with Pulse → Width Output
SMLD	Manual Station
SMST	Auto / Manual Station
SMRT	Ratio Set Station
SCMS	Programmable Computing Station
SBSD	Batch Set Station
SLCC	Blending Controller
SLBC	Batch Controller
STLD	Totalizer

### 3. NAME OF COMPONENTS AND TERMINAL DESIGNATION OF POWER SUPPLY

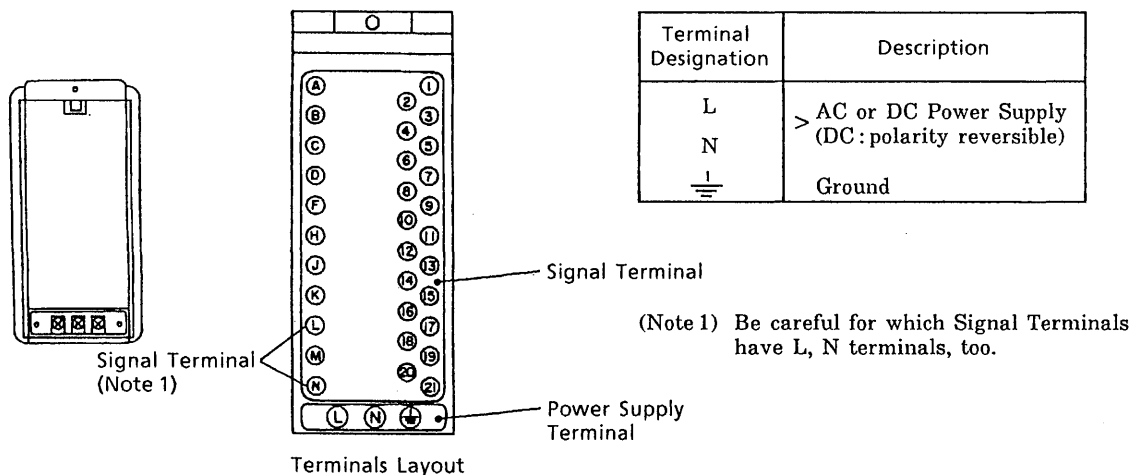

### 4. POWER SUPPLY AND GROUND WIRING.

- (1) All cable ends must be furnished with crimp-on type solderless lugs (for 4mm screw).
- (2) Examples of applicable cables.

Cross-sectional area of the cable conductor : 2.0mm<sup>2</sup>.\*

Note \* : Power supply cables should be determined from the instrument power consumption - they must have conductors with cross-sectional area of at least 1.25mm<sup>2</sup>.

Applicable cable : 600V vinyl insulated cable (IV), conforming to JIS C3307.

Vinyl sheathed cables for electric appliances (KIV), conforming to JIS C3316.

- (3) After completing the power supply and ground wiring, mount the power terminal cover.